



SPORTING AND TECHNICAL REGULATIONS

VRM BMW M2 CUP
POWERED BY  **HANKOOK**

Promoter / Organisation: V-Max Racing Management B.V. (VRM)

Contacts: Dick van Elk
Schapendreef 78
4824 AM BREDA - Netherlands

Tel. No.: +31 765430200
Mobile No.: +31 653798219

Homepage: www.vrm-m2cup.nl
E-mail: dickvanelk@vrm-m2cup.nl

Table of Contents

Part 1 Sporting Regulations

- 1. Introduction**
- 2. Organisation**
 - 2.1 Details on Titles and Awards of the Series
 - 2.2 Name of the Parent ASN
 - 2.3 ASN Visa / Registration Number
 - 2.4 Name of the Organiser / Promoter, Address and Contacts (Permanent Office)
 - 2.5 Names of the Permanent Stewards
- 3. Regulations and Legal Basis of the Series**
 - 3.1 Official Language
 - 3.2 Responsibility, Modification of the Regulations, Cancellation of the Event
- 4. Entries**
 - 4.1 Entry Fees for the Season
 - 4.2 Competition Numbers
- 5. Licences**
 - 5.1 Required Grade of Licence
 - a) Driver
 - b) Entrant
 - c) Guest Driver
 - d) Age Regulations
 - 5.2 Conditions for Entrants Outside their National Territory
- 6. Insurance, Exclusion of Liability and Disclaimer**
 - 6.1 Organiser's Insurance
 - 6.2 Declaration by the Entrant, Driver and Passenger on the Exclusion of Liability, Disclaimer of the Vehicle Owner
- 7. Events**
 - 7.1 Calendar of Series Events
 - 7.2 Maximum Number of Cars authorised
 - 7.3 Running of the Events
 - a) Practice
 - b) Qualifying
 - c) Starting Modes
 - d) Races
- 8. Classification**
 - 8.1 Points Table
 - 8.2 Equal points
 - 8.3 Official Classification Table and Entry List
 - 8.4 Points Table for "Drivers' and Team Classification"
- 9. Private Practice and Testing**
- 10. Administrative Checks**
 - 10.1 Administrative Checks Schedule
 - 10.2 Drivers' Meeting / Briefing
- 11. Scrutineering / Technical Checks**
 - 11.1 Repair, Sealing and Marking of Vehicle Parts
 - 11.2 Schedule Scrutineering / Technical Checks

- 12. Races**
 - 12.1 Usage of Wet Tyres
 - 12.2 Maximum Number of Persons working on a Car
 - 12.3 Pit Stop Safety and Competitor's Responsibility When Starting from the Pit Area
 - 12.4 Drivers Mandatory pitstop in a race
 - 12.5 Refueling during pitstops
 - 12.6 Engines during a pitstop
 - 12.7 Penalties for not following pit stop procedure

- 13. Title and Trophies**
 - 13.1 Title Overall Winner
 - 13.2 Trophies
 - 13.3 Disqualification from the BMW M2 CS Racing Cup, Exclusion from Classification, Withdrawal of Prizes
 - 13.4 Awards Ceremony

- 14. Protests and Appeals**

- 15. Exclusion of Jurisdiction of a Court and Limitation of Liability**

- 16. TV Rights / Advertising and Television Rights**

- 17. Specific Regulations**

Part 2 Technical Regulations

1. Technical Series Regulations

- 1.1 Summary of the Eligible Groups / Classes
- 1.2 Principles of the Technical Regulations
- 1.3 General / Preamble
- 1.4 Driver's Equipment
- 1.5 General Regulations, Permitted Modifications and Installations
 - 1.5.1 Ground Clearance
- 1.6 Minimum Vehicle Weights and Ballast
- 1.7 Exhaust Prescriptions
- 1.8 Noise Regulations
- 1.9 Advertising Regulations and Start Numbers on the Vehicles
- 1.10 Safety Equipment
- 1.11 Fuel and Standard Fuel
 - 1.11.1 Fuel check
 - 1.11.2 Refueling, tank system and checks
- 1.12 Technical Definitions

2. Specific Technical Regulations

- 2.1 General
- 2.2 Engine
 - 2.2.1 Exhaust System
- 2.3 Transmission
- 2.4 Braking System
- 2.5 Steering
- 2.6 Suspension
- 2.7 Wheels (Flange + Rim) and Tyres
- 2.8 Bodywork and Dimensions
 - a) External Bodywork (Including Windows)
 - b) Cockpit
 - c) Additional Accessories
 - d) Track Width
- 2.9 Aerodynamic Devices
- 2.10 Electrical Equipment
- 2.11 Fuel Circuit
- 2.12 Lubrication System
- 2.13 Data Transmission
- 2.14 Other

Part 3 Attachments / Drawings

- 1: Advertising and Labelling on the Vehicle in accordance to the Series Regulations

This regulations consists of 28 pages

Part 1 Sporting Regulations

1. Introduction

The series VRM BMW M2 Cup is organised in accordance with the provisions of the International Sporting Code and its appendices (the Code), the FIA's general prescriptions on circuit racing and the National Sporting Regulations of the Belgian ASN, the Royal Automobile Club of Belgium. It will be run in accordance with the Series' Sporting and Technical Regulations, the latter being in accordance with the safety prescriptions of FIA Appendix J (Article 253 respectively 277). The Cup has the status of National Championship (under the Zone Regulation guidelines) with authorized foreign participation. Events will be organised according these regulations and the Supplementary Regulations of the Events.

The series is supported by the following companies:

MAGLR.COM
HANKOOK

2. Organisation

2.1 Details on Titles and Awards of the Series

For 2021, the series organiser organises the VRM BMW M2 Cup as part of the events on the calendar as mentioned in Art. 7. The participation in this Cup is reserved exclusively for the BMW M2 CS Racing cars which comply to part II, Technical Regulations.

2.2 Name of the Parent ASN

RACB – Royal Automobile Club of Belgium
Rue d'Arlon 53/3
B – 1040 Brussels
Belgium

2.3 ASN Visa/Registration Number

The series based on these Sporting and Technical Regulations has been approved by the RACB on 30.03.2021 with visa number S02-BMWC/B21.

2.4 Name of the Organiser/Promoter, Address and Contacts (Permanent Office)

V-Max Racing Management B.V. is the sole organiser.

Only the organiser may be contacted with questions regarding the sporting and technical regulations at the events.

V-Max Racing Management B.V.

Schapendreef 78
4824 AM Breda
NETHERLANDS

2.5 Names of the Permanent Stewards

N/A

3. Regulations and Legal Basis of the Series

This series is governed by the following regulations:

- FIA International Sporting Code (ISC) and its appendices;
- National Sport Code (NSC) of the RACB;
- Anti-Doping Regulations of the national and international Anti-Doping Agency (WADA/NADA Code), as well as the anti-doping regulations of the FIA;
- Sporting and Technical Regulations of this Series and the RACB approved modifications and supplements (Bulletins);
- Supplementary Event Regulations including modifications and supplements (Bulletins);
- FIA Code of Ethics and Code of Conduct;
- Other Regulations of the FIA and the RACB.

Changes to the regulations are, in accordance with the RACB, also possible during the season. Each change to the regulation must be approved by the RACB and the participants will be informed in writing through a bulletin and a publication on the RACB website

Anything not explicitly permitted in these regulations is prohibited with regard to the VRM BMW M2 Cup. Furthermore, the series organiser refers to the supplementary regulations of the relevant organiser.

These general regulations, combined with the supplementary regulations of the event organiser, are valid for all races without exception.

The hosting and organisation of an event (free practices, qualification and races) is the sole responsibility of the organiser, meaning that all participation requirements and obligations of the organiser with regard to this cup class must be complied with.

If one of the provisions above is to become void, this does not affect the effectiveness of the remaining provisions and agreements.

For questions that arise of these general regulations, contact the series organiser.

3.1 Official Language

The official language for these regulations is English. Only the English and RACB approved text of regulations will be binding.

3.2 Responsibility, Modification of the Regulations, Cancellation of the Event

- (1) The participants (= entrants, drivers, passengers, vehicle proprietors and registered keepers) take part in the event at their own risks. They carry the exclusive responsibility under civil and criminal law for all the damages caused by them or the car used by them as far as no exclusion of liability has been concluded.
- (2) Modifications to these regulations may in principle be carried out only by the relevant authorities. After the beginning of the event, modifications should be carried out only by the Stewards of the event by means of bulletins, but only in case of necessity for safety reasons and/or reasons of force majeure, or by order of the authorities, or concerning the details given in the regulations about the length of the track, the duration of the races, the number of laps and the officials and marshals, or in case of an obvious mistake in the regulations.
- (3) The series organiser and the event promoter reserve the right to cancel or postpone the event or individual races for the aforementioned reasons, subject to the agreement of the respective ASN and the FIA, if it affects the calendar. Compensation or claims for performance are excluded in this case.

4. Entries
4.1 Entry Fees for the Season

The registration fee for the Championship with six (6) events according to the calendar (see Art. 7) is set at € 10.500,- ex VAT.

4.2 Competition Numbers

The participants will get competition numbers for the entire season, assigned by the organiser.

5. Licences
5.1 Required Grade of Licence

a) Drivers

Drivers holding a valid 2021 national C-Circuit driver's licence, issued by the RACB or by another ASN affiliated to the FIA.

b) Entrant

Entrants wishing to register with the driver must be in possession of a valid 2021 National entrant licence issued by the RACB or by another ASN affiliated to the FIA.

c) Guest Driver

N/A

d) Age Regulations

- In accordance with the valid RACB Licence Regulations
- Each driver must be aged 16 or over at the time of the event.

5.2 Conditions for Entrants Outside Their National Territory

For events with the status "National Event with Authorized Foreign Participation" (NEAFP) participants with an RACB licence as well as a licence of another FIA affiliated ASN are allowed to participate and get points.

Foreign competitors / drivers have to present the approval of their own ASN. This permission must be submitted by the competitor/driver at Administrative Checks in English language.

6. Liability Exclusion and Disclaimer
6.1 Organiser's Insurance

In accordance with RACB National Sporting Code.

6.2 Declaration by the Entrant, Driver and Passenger (=Participant) on the Exclusion of Liability, Disclaimer of the Vehicle Owner

According to RACB National Sporting Code.

Participants irrevocably renounce the right to claim for damages in connection with the event, against the V-Max Racing Management B.V., its bodies, employees and agents.

7. Events

7.1 Calendar of Series Events

0	April 9 - 2021	Press and testday (not included in events)
1	April 10 + 11 - 2021	Openingsraces Zandvoort
2	June 4+ 5 + 6 - 2021	Spa Euro Race
3	July 16 + 17 + 18 - 2021	Zolder Supercar Madness
4	September 17 + 18 + 19 - 2021	DTM Assen
5	October 16 + 17 - 2021	Racing Festival Spa
6	October 29 + 30 + 31 - 2021	Finaleraces Assen
X	November 13 - 2021	10H Race promotion Night Zolder (optional)

7.2 Maximum Number of Cars Authorised

The maximum number of cars permitted on track is defined following the circuit licence and listed in the supplementary regulations for the individual events.

7.3 Running of the Events

a) Practice

At least two timed practices are scheduled for each event (for details, see the supplementary regulations for each event).

b) Qualification

At least one session is scheduled for each event (for details, see the supplementary regulations for each event). Each car must complete at least one (1) timed practice lap. Failure to provide evidence of this may result in the car not being allowed to take part in the race. The Stewards decides about exceptions on the basis of a written application from the entrant / driver

c) Starting Modes

The races will be started as follows:

- Rolling start (Indianapolis start)

d) Classification Races

The races will run over a distance of one hour.

8. Classification

8.1 Points Table

The 2021 VRM BMW M2 Cup comprises a total of 6 classification events (twelve races).

It is possible to take part as single driver or as a team of two or three drivers. A team may consist of three participants at most. It is a condition that each of these participants drive at least four (4) races for the team.

To be classified in the Cup classification at an event and therefore receive points for the team and/or drivers' standings, one must have completed 75% of the required race distance in accordance with the Supplementary Event Regulations. Should the race distance be reduced, for whatever reason, the points awarded will be as in a race over the normal distance.

BMW Dealer Team Classification

Prerequisite for the classification in the BMW Dealer Team classification is, that startnumber/car, driver (pairing) is registered for the Dealer Team competition. If a team change is made by a driver, the transfer of points gained so far is precluded.

A maximum of three (3) vehicles per BMW dealer team can score points in the team classification. If there are more than three (3) vehicles per dealer team, the team must decide with which vehicles they want to score points. The team representative has to submit the nomination of the vehicles and the specific competition numbers in written form to the organiser no later than the start of the first event. The nomination cannot be submitted later. In this case VRM will submit the nomination of three (3) vehicles with the three lowest competition numbers of the entrant by its own decision to the organising committee. Any submitted nominations for the team classification are valid for all events until withdrawal or change in consideration of the notification deadlines.

8.2 Equal Points

If more than one driver or team has the same number of points as their final score, the larger number of first places then second places and further places of all races held will decide the ranking.

8.3 Official Classification Table and Entry List

The official classification table can be found at <http://www.vrm-m2cup.nl>.

8.4 Points Table for "Drivers', 'Trophy' and Team Classification"

The following points will be awarded equally to all drivers (pairings) of a vehicle who start the relevant event in this vehicle for the purpose of this classification.

For the team classification only the BMW Dealer team's best placed three vehicles, as long as the vehicle is nominated for the team classification, will receive points.

Position:	Points:
1st	23
2nd	20
3rd	17
4th	15
5th	13
6th	11
7th	9
8th	7
9th	5
10th	3
11th	1

For each race, an overall race result and a ranking per class will be drawn up. If two or three drivers are participating in the same car as a registered team, all receive points corresponding to

the result achieved. There is one point for pole position (1 point) for the first race. The fastest time in qualification is for the pole position of race 1, the second fastest time in qualification is for the pole position for the second race.

9. Private Practice and Testing

There are no limitations outside the official events for private practices and testing.

10. Administrative Checks

The national sport authority of the visited country is responsible for performing the administrative checks. It can delegate this function to VRM.

The following documents must be presented by the driver / entrant:

- Entry confirmation
- Entrant's/driver's licence
- Driver's licence
- Authorisation to take part in an event abroad

10.1 Administrative Checks Schedule

See relevant Supplementary Regulations for the event or official notice board.

10.2 Drivers' Meeting / Briefing

See relevant Supplementary Regulations for the event or official notice board.

Attendance over the complete duration of the drivers briefing is mandatory for all drivers and they must confirm their attendance by personal signature in the list of attendees.

Any non-attendance or failure to be present throughout the complete duration will automatically result in a fine of 150€ inflicted by the Stewards of the Meeting and has to be transferred to the parent ASN.

11. Scrutineering / Technical Checks

The visiting ASN and the organiser are responsible for performing technical scrutineering. The drivers or their representatives must present their race car and the compulsory driver's safety equipment at the scrutineering. The car must be presented in the configuration as it will be used in the competition (incl. start numbers) and it must comply with the applicable technical regulations of the relevant organiser. Furthermore the individual event regulations are applicable.

Presenting a vehicle for scrutineering is deemed to be the participants' implicit confirmation that the vehicle in question conforms to all points of this regulation and the relevant organiser's supplementary regulations.

The following vehicle documents must be presented:

- Technical passport
- Certificate for rollover structure
- Certificate for fuel tank

Technical checks can be ordered at any time in agreement with the stewards. See part 2 of this regulation.

The scrutineer may check the complete vehicle during the inspection. During the event, the scrutineer, in agreement with the stewards, may check any vehicle or vehicle parts, irrespective of its position. Each entrant is obliged to dismantle their vehicle for a technical inspection at their

own cost if asked to do so by the scrutineer, and then to reassemble it.

The scrutineer can compare individual parts with those in the sample kit to decide whether a part of a participant's vehicle that was dismantled for inspection is permitted or not. Sample kits are provided upon request by the series organiser.

The series organiser can inspect cars at any time. If necessary, in agreement with the scrutineer, vehicle parts or the whole vehicle can be seized by the series organiser to facilitate detailed inspections. If any manipulation is determined, all related costs incurred are to be paid by the entrant. If the vehicle conforms to these regulations, the series organiser covers the costs.

11.1 Repair, Sealing and Marking of Vehicle Parts by BMW Motorsport

Sealed parts (see below for a binding list) must not be opened by the participants themselves. If the seals have been manipulated, the affected component may no longer be used in official events. In any case this will result in the stewards and series' organiser being notified and may result in exclusion from the classification for the event.

If seals are damaged or missing, this has to be reported to the responsible scrutineer immediately and in writing. The scrutineer is responsible for deciding whether the component in question can be resealed after inspection and therefore be used during events.

List of sealed components:

- Engine (turbocharger, throttle valve, 2x cylinder head)
- Performance-relevant sensors (2x boost pressure sensor)
- Control units (engine / ABS)

Control units are usually labelled (e.g. hologram) and identified by a sequential number.

11.2 Schedule Scrutineering / Technical Checks

See corresponding Supplementary Regulations or official notice board.

The exact scrutineering times and place will be published in the entry confirmation.

12. Races

12.1 Usage of Wet Tyres

The number of wet tyres is not restricted. During the events, the participants have to adhere to the tyre regulations stipulated in part II Art. 2.7.

12.2 Maximum Number of Persons working on a Car

The maximum number of Persons working on the car during races (pitstops) is limited to four (4).

12.3 Pit Stop Safety and Competitor's Responsibility when Starting from the Pit Area

See corresponding Supplementary Event Regulations.

12.4 Driver's mandatory pit stop in a race

During the race there is at least one mandatory pit stop of 60 seconds for possible driver's change. During this pit stop working on the car is permitted, there is a limitation of four (4) people working on the car.

The time for entering and exiting the pit lane will be added to the time for this pit stop. The total time will be checked electronically using the loops at the pit lane entrance and pitlane exit. The total time will be announced for each event through an event bulletin. A car therefore does not have to be stationary for exactly 60 seconds but needs to be between the loops for the minimum time.

When entering and exiting the pit lane the maximum permissible speed, as stated in the Supplementary Regulations and/or Driver's Briefing notes will be usually 60 km/h, should be respected at all times. If a participant is held up by someone driving away too slowly, the Race Director may impose a penalty for obstructing other participants. Under all circumstances, the driver must be securely fastened in the safety belts.

During a Safety Car situation or FCY, entering the pit lane for the mandatory 60-second pit stop is permitted.

The exact time for the pitstop will be published in a bulletin. The pitstop itself must commence between the 25th and 35th minute of the race.

12.5 Refuelling during the pitstop

Because of the limited size of the fuel tank (84 litres) and the length of the races, refuelling of maximum 20 litres during the pitstop is permitted under the following conditions:

20 litre steel jerry cans, with a fixed hose of max. 50 cm length measured from the tap c.q. tap with a self-closing ball valve, optionally provided with a vent valve approved by the TC and marked with a TV 2021 sticker.

During refuelling the arriving driver must remain in the car (changing driver is not yet allowed). Both the mechanic for the refuelling as the supervisor with a handheld fire extinguisher of 5 kg minimum must wear full protective clothing including, gloves, balaclava and goggles. The personnel tasked with refuelling have to be completely covered by fireproof clothing including a balaclava and gloves. A drip tray as well as a mat must be used during refuelling. The 'lollypop man' needs to stand next to the car during refuelling. The driver change and all other activities are permitted only after refuelling. During refuelling, all doors and windows must remain closed. If wheels have to be changed the engine must be switched off.

Any breach of these provisions relating to refuelling will entail penalties at the discretion of the Clerk of the Course or Race Director or Stewards of the Meeting up to the disqualification of the car and driver(s) concerned from the event.

12.6 Engines during the pit stop

During the pit stop, engines may continue to run to prevent cooling problems as long as no tyres are changed or any other mechanical interventions. A mechanic with a handheld fire extinguisher of minimal 5 kg, must be on hand for incidents.

12.7 Penalties for not following pit stop procedure

- If the car is not between the measuring loops for the required number of seconds: drive through, time penalty or one penalty lap.
- If the pit stop is made too early or too late: drive through, time penalty or one penalty lap.
- If the pit stop is not made at all: five penalty laps.

13. Title and Trophies
13.1 Title Overall Winner

The title:

Champions VRM BMW M2 Cup 2021

will be awarded to the driver or driver pairing that has scored the highest number of points after all of the classification events in the VRM BMW M2 Cup. The attendance of first three drivers or teams during the RACB Awards Ceremony in 2021 is mandatory.

The “Champion VRM BMW M2 CS Cup 2021” and potential vehicle owner promise to provide the winning vehicle at the request of BMW M free of charge to be exhibited at one event located in Germany (e.g. “Essen Motor Show 2021” exhibition).

The title:

Trophy VRM BMW M2 Cup 2021

will be awarded to the Trophy driver or Trophy driver pairing that has scored the highest number of points after all of the classification events in the VRM BMW M2 Cup. The attendance of the driver or team winning this title during the RACB Awards Ceremony in 2021 is mandatory.

The title:

BMW Dealer Team Champion VRM BMW M2 Cup 2021

will be awarded to the team which has scored the highest number of points after all of the classification events in the VRM BMW M2 Cup 2021. The attendance of the team winning this title during the RACB Awards Ceremony in 2021 is mandatory.

The “BMW Dealer Team Champion BMW M2 Cup 2021” and potential vehicle owner promise to provide the winning vehicle at the request of BMW M free of charge to be exhibited at one event located in Germany (e.g. “Essen Motor Show 2021” exhibition).

13.2 Prizes and Trophies

(1) Classification

(a) Driver’s Classification

The top three Overall driver pairings will receive trophies at the awards ceremony after each race. Each driver pairing will receive a trophy. The awards ceremony will take place in accordance with organiser’s regulations.

(b) Trophy Classification

Furthermore, the top three Trophy Driver pairings at the end of each race receive a trophy at the award ceremony.

(c) BMW Dealer team Classification

Furthermore, the best placed Dealer Team receives a trophy at the award ceremony.

2 Annual Trophies

(2) Annual Drivers’ Classification

(a) Trophies

The top three overall drivers or team pairings will each receive a trophy at the annual award ceremony.

(3) Annual Team Classification

(b) BMW Dealer Team Trophy

The BMW Dealer Team Champion will also receive a trophy at the annual award ceremony.

(4) Junior Classification

A driver is classified as Junior, when he / she does not turn 25 in the running season. As such, drivers born in 1997 may be classified in the Junior classification for the last time in the 2021 season.

The best-placed Junior in the Drivers' classification at the end of the season, after all the races and discards, receives a trophy at the annual award ceremony. He / she also receives the title:

Junior Champion VRM BMW M2 Cup 2021

(5) Trophy Classification

Drivers aged 45 or above in the year in question are classed as Trophy Driver. As such, drivers born in 1976 may be classed as Trophy Driver for the first time in the 2021 season. The best-placed Trophy Driver in the Drivers' classification at the end of the season, after all the races and discards, receives a trophy at the annual award ceremony. He or she also receives the title:

Trophy Champion VRM BMW M2 Cup 2021

13.3 Disqualification from the VRM BMW M2 Cup, Disqualification from Classification, Withdrawal of Prizes.

If these Supplementary Regulations, Sporting Regulations, Technical Regulations, special provisions are violated, or in the event of unsporting behaviour, particularly unsporting driving, depending on the severity of the offence, the stewards may disqualify the offender from classification in the event in question, or the sports court may disqualify the offender from the VRM BMW M2 Cup altogether.

An appeal against the disqualification is the responsibility of the RACB Sport Court.

13.4 Awards Ceremony

After each racing event an awards ceremony will take place. The award ceremony forms part of the event. The top three drivers (pairings), the three Trophy pairing and the winning Dealer team will be honoured by the organiser. Participation is mandatory. Absence will be penalised through withholding the trophy. Special dispensation may be granted upon a written request to the series' organiser.

The awards ceremony for the season in the VRM BMW M2 Cup will take place as part of the annual VRM Series award ceremony at the end of the year. The top three driver pairings, the top three BMW Dealer teams, the best Junior, the best Trophy driver will be honoured. These will be informed in writing in advance by VRM. The participation is mandatory.

Absence will be penalised through withholding the trophy. Special dispensation may be granted upon a written request to the series' organiser.

14. Protest and Appeals

The FIA International Sporting Code and the RACB National Sporting Code are applicable.

Protest deposit – payable to the RACB: 500,00€
Appeal deposit – payable to the RACB: 2.000,00€
Appeal to the FIA – payable to the FIA: 6.000,00€
(Protest and appeal deposits are exempt from VAT)

15. Rejection of Legal Action and Exclusion of Liability

- (1) The jurisdiction of a court is excluded for decisions made by the FIA, the RACB, their jurisdictions, the stewards, the series' organiser or the organiser as judge.
- (2) No claim for compensation of any kind whatsoever may be derived from actions and decisions made by the RACB or its jurisdiction, or by RACB representatives or the series' organiser, except in the case of a damage caused on purpose or by gross negligence.

16. TV Rights / Advertising and Television Rights

Irrespective of §3, the corresponding Supplementary Event Regulations have priority here.

If the organiser has not included any regulations, or no complete regulations regarding this matter in the supplementary regulations, the following applies:

The series' organiser or third-party acting with their consent have the right to use images, texts, reports and race results regarding the VRM BMW M2 Cup, or to reproduce these in changed or unchanged form without restriction on space, time, or content and without additional payment, for the purpose of internal and external corporate communications, including advertising purposes. The entrant grants the series organiser this right of use and guarantees that the driver, co-driver and (if different) the owner of the vehicle used, as well as all other persons involved grant the same rights. The series' organiser holds all image rights, including the images used in television broadcasts of the VRM BMW M2 Cup. All television rights for the VRM BMW M2 Cup, including terrestrial broadcast as well as cable and satellite television broadcast, all video rights and all rights regarding the use of all electronic media, including the internet, are held by the series' organizer.

Any kind of recording, broadcast, repetition or reproduction for commercial purposes without the written consent of the series' organiser is prohibited.

It is permitted to install a "AIM Smarty Cam", connected to the AIM Datalogger. Additionally, the installation of a GoPro cam for TV footage by the team or the organisation is permitted. Scrutineers will check the safe mounting of the cameras.

Furthermore, reference is made to 2. Art. 2.9 (Part 2) of these regulations.

17. Specific Regulations

There are no additional Specific Series Regulations.

Part 2 Technical Regulations

1. Technical Series Regulations

1.1 Summary of the Eligible Groups / Classes

One class: The only eligible vehicle is the BMW M2 CS Racing and its existing versions produced specifically for this purpose. Eligible to participate are the following:

- 450hp version, as supplied by BMW Motorsport
- 365hp version, as supplied by BMW Motorsport with the fully installed upgrade kit. The ballast box may be removed as long as the minimum weight is respected.

Here the basis is the BMW M2 CS (F87) from the Series production.

In the VRM BMW M2 Cup only vehicles which comply to the technical specifications can be used. Also refer to part 2, Art. 1.5.

1.2 Principles of the Technical Regulations

- General regulations, definitions and clarifications with regard to technical regulations (FIA Yearbook)
- The most recent version of the parts catalogue for the BMW M2 CS Racing
- The most recent version of the user manual for the BMW M2 CS Racing
- Supplementary Event Regulations, part I of this regulation including all attachments

Furthermore, the rules also apply for the administrative checks and scrutineering / technical checks outlined in Art. 10 and 11 of part 1 of these regulations.

1.3 General / Preamble

Everything not explicitly allowed by these regulations is prohibited. Permitted modifications must not result in unauthorised modifications or infringements of the regulations.

The aim and purpose of these regulations is to enable every participant to be competitive in the class without investing in modifying or further developing the vehicle.

The parts catalogue for the BMW M2 CS Racing fundamentally defines the race car. Deviations from this catalogue must be approved by these Technical Regulations or they are deemed to be inadmissible.

1.4 Driver's Equipment

The wearing of overalls homologated to the FIA 8856-2000 or 8856-2018 standard as well as underwear (with long sleeves and legs), balaclava, socks, shoes and gloves in compliance with the FIA prescriptions is compulsory.

Furthermore, a helmet must be worn in compliance with the FIA regulations (Appendix L of the ISC).

In addition, the use of the FIA-head restraint (e.g. HANS®) is compulsory.

1.5 General Regulations, Permitted Modifications and Installations

The BMW M2 CS Racing must conform with these regulations throughout the entire event.

The participant / entrant is responsible for making sure that the vehicle is used only in a state that is flawless from a technical perspective and that the RACB safety regulations are adhered to at all times.

Changes to the parts catalogue and therewith the vehicle specification made by BMW AG are confined to safety improvement or costs reduction. Additionally, it may be necessary to make updates based on changes to the parts catalogue of the base vehicle.

All installations performed by the entrant / participant may only fulfil the intended function. The scrutineer will decide whether this is the case.

Work necessary for the normal servicing of the vehicle, or the replacements of wearing or damaged parts caused by an accident may be carried out.

Modifications and installations are only allowed according to the following specifications. Any part worn through use or accident may only be replaced by an original part identical to the damaged one.

Throughout the car, the attachment standard parts, such as nuts, bolts, washers, lock washers, spring washer, splint pins may be replaced with comparable standard parts to the original shape. With regard to screw threads, thread type, size and pitch (e.g. M 8 x 1.25) must be retained. Screw threads may be strengthened by Heli-Coil.

The entrant / driver / owner is hereby informed that the BMW M2 CS Racing car (as supplied) may only start in this Cup class at events, at which a Cup class generated specifically for this car is available. Should the organiser not provide a Cup class generated specially for this car, the organiser is obliged to classify the car in an appropriate class and, where necessary, to integrate it using a "Balance of Performance". An exceptional approval to take part in a different class may only be granted by BMW M Customer Racing and must be applied to the respective organiser.

1.5.1 Ground Clearance

The ground clearance is measured with an empty fuel tank and without a driver. On the vehicle the measuring points are shown as follows on the surface:

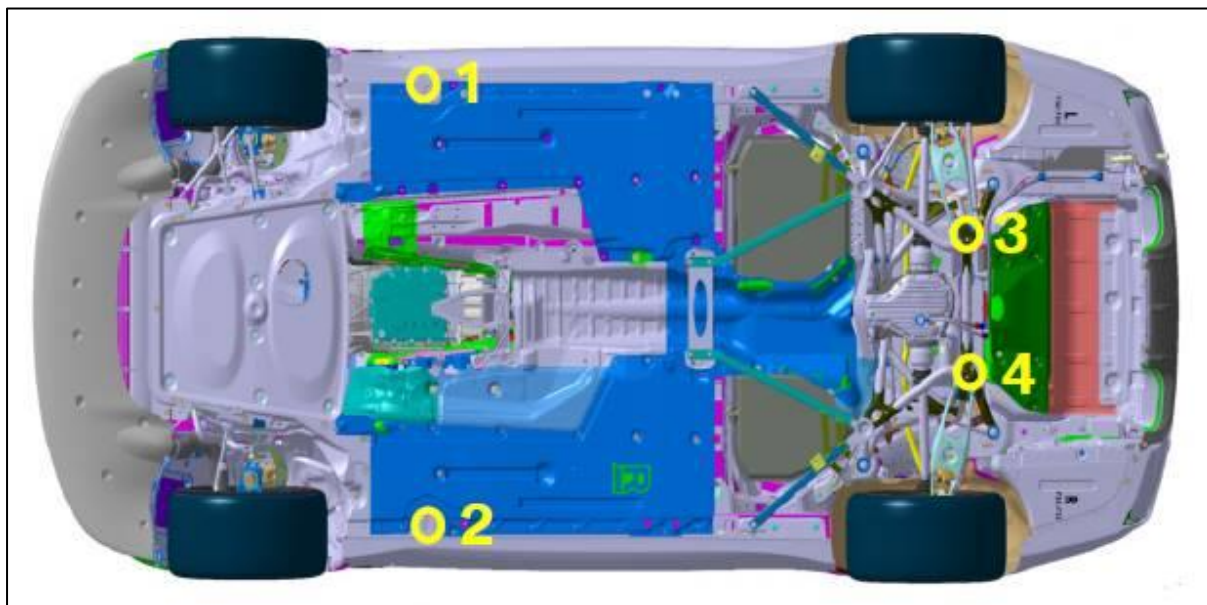

Measuring point



measuring point front axle



measuring point rear axle

The ground clearance must measure a minimum of 130mm.

The organiser will define a reference area for measuring the ground clearance before the start of the event.

The tyre pressure may be raised to the reference pressure (2.4 bar FA; 2.3 bar RA) for measuring. The measuring of the ground clearance is done during the inspection of the fitted tyres.

1.6 Minimum Vehicle Weights and Ballast

Before the start of the event, the organiser determines the scales for measuring the minimum vehicle weight,

The minimum weight of the vehicle including driver in full gear is 1625 kg. During the event the weight of the vehicle must at all time remain at least this minimum vehicle weight. The vehicle will be weighed with an empty fuel tank and with a driver. In case of two drivers the average weight will be calculated. Utilities may not be refilled.

If the vehicle was damaged during the competition, the weight of the parts lost in the process can be considered at the scrutineer's discretion.

It is permitted to add ballast to the vehicle to conform with the weight regulations. As outlined in the parts catalogue, this ballast must be composed of fixed, uniform blocks and be attached to the floor of the passenger compartment. The ballast weight will be sealed. The screw defined in the parts catalogue is to be used for this.

RACB Note:

The RACB guidelines for vehicle weighing (including calibration or calibration of balances) needs to be respected by the series organiser. According to the guidelines, mobile scales must be inspected, at least annually, by the weighing machine manufacturer. In exceptional cases, a calibration / verification by a state calibration authority is permitted. The scale must be calibrated at least every 2 years by the manufacturer.

1.7 Exhaust Prescriptions

The current RACB exhaust prescriptions must be adhered to.

The vehicles must be equipped with the fitted catalytic converter in compliance with the RACB exhaust prescriptions.

1.8 Noise Regulations

The maximum permitted noise limit is according to the limit per event specified in the

Supplementary Regulations.

1.9 Advertising Regulations and Start Numbers on the Vehicles

The current FIA / RACB regulations for start numbers and for advertising on drivers' equipment and vehicles (see FIA ISC) must be adhered to.

NOTE: Deviations from the FIA / RACB regulations require a special approval from the RACB.

Taking the FIA / RACB regulations for start number and advertising on the vehicles into account, the following advertising is compulsory on the race car. See part 3, attachment 2 of these regulations.

The sticker regulations of VRM apply.

Areas not required by the series organiser, which are also not claimed by the organiser of the respective event and are not marked on the drawing, may be used by the participants to display their own sponsors, providing the sponsors in question are not in competition with the series organiser in the field of the production and distribution of automobiles (including parts and accessories), as well as vehicle financing, leasing, and mobility services. The participant's sponsors must also not be in competition with the sponsors of the series organiser. Any exemptions from this must be requested in writing from the series organiser.

For the driver's equipment the following special advertising regulations apply. The series organiser has the right to design and place advertising on any area of the driver overall and vehicle. To which extend this right is used by the series organiser is defined in the attachment of these regulations. The drawings in the attachment are part of the regulations.

The participants commit themselves, to place the series organiser as well as the event organisers' patch on the overall and to leave it there for the entire event period. The patches will be determined regarding size, type, number and position (see space for patches in attachment 1). To the patches of the series and event organiser there must be a minimum distance of 10 mm to the team specific patches.

The advertising regulations are part of the regulations. The non-compliance of these guidelines will be punished with a fine of € 2.500,- per infringement / event to VRM.

This is referenced to the attachment 1 and 2 of these regulations as well as to the series organiser's regulations.

1.10 Safety Equipment

The vehicles must have the following safety equipment.

Unless stated otherwise, the article numbers refer to the current Appendix J ISC.

- Lines and pumps in accordance with Art. 253.3.1 and 253.3.2, or Art. 259.6.2
- Oil catch tank in accordance with Art. 259.7.4
- Fuel cell ventilation in accordance with Art. 253.3.4
- Double circuit braking system in accordance with Art. 253.4
- Additional safety fastener in accordance with Art. 253.5
- Safety belts in accordance with Art. 253.6, or Art. 259.14.2.1
- Manual extinguisher in accordance with Art. 253.7.3
- Fire-extinguishing system in accordance with Art. 253.7.2 and Art. 275.14.1
- Safety cage in accordance with Art. 253.8
- Safety cage in accordance with Art. 253.8 (Appendix J 1993)
- Safety cage in accordance with Art. 277

- Rear view mirror in accordance with Art. 253.9
- Towing-eye / device in accordance with Art. 253.10 and Art. 259.14.6
- Safety foil on the windows in accordance with the RACB prescriptions
- Windshield made of laminated glass
- Door nets in accordance with Art. 253.11 or with the RACB prescriptions
- Additional safety fixing devices for windshield in accordance with Art. 253.12
- General circuit breaker in accordance with Art. 253.13
- Safety fuel tank in accordance with FIA standard FT3 / FT3-1999
- FIA homologated non-return valve in the filler neck in accordance with Art. 253.14.5
- Fireproof screen in accordance with Art. 253.15 and Art. 259.16.6
- Seats and attachments in accordance with Art. 253.16
- FIA homologated driver seat in accordance with Art. 253.16
- Headrest in accordance with Art. 259.14.4
- Rear light in accordance with Art. 275.14.5
- Reverse gear in accordance with Art. 275.9.3
- Prohibition of pressure control valves in accordance with Art. 253.17
- Article 277
- In accordance with the Appendix K to the ISC

1.11 Fuel and Standard Fuel

The following single fuel must be used supplied by the organiser VRM: Postma 101 Power.

1.11.1 Fuel Check

At any time during the event the stewards may extract fuel samples.

1.11.2 Refuelling, tank system and checks

It is allowed to refuel during the races. See part 1, Art 12.5

1.12 Technical Definitions

In addition to the definitions in accordance with this article and article 3.3 (Part 1) of these regulations, the “General regulations, definitions and clarifications to the Technical Regulations” as well as the definitions according to Art. 251 of the Appendix J (ISC) are applicable.

2. Specific Technical Regulations

2.1 General

In addition to the Technical Regulations according to part 2 of these regulations, the following specific technical regulations are applicable.

Everything which is not explicitly allowed by these regulations is prohibited. **Permitted modifications must not result in any illegal modifications or infringements of the regulations.**

2.2 Engine

The engine will be sealed before the first event. Any changes to the engine or its attachments are prohibited (see Part 1, Art 11).

2.2.1 Repairs, Sealing and Labelling vehicle part by VRM

List of sealed and labelled parts:

- 2x Hologram on the DME control unit
- 1x Hologram on the pressure temperature intercooler
- 1x Hologram on the pressure temperature sensor induction pipe
- 1x Sealing of the valve cover / turbo charger front
- 1x Sealing of the valve cover / turbo charger rear

2.2.2 Exhaust System

The exhaust system outlined in the parts catalogue has to be used.

2.3 Transmission

The gearbox and the differential will be delivered non-sealed. Any changes to the gearbox or differential are prohibited. Checks, revisions, or opening may only be carried out by VRM and the scrutineer.

2.4 Braking System

The entire braking system and its parts subject to wear are only to be obtained from by VRM appointed suppliers.

The braking system is different from the series vehicle and is defined by the parts catalogue. The driving aids (ABS, DSC and MDM) are tuned specifically for use on a racetrack and must not be changed by the entrant.

The vehicle variation with 450PS version is to be operated with the provided braking system its wear part from the parts catalogue.

The choice of brake pads is not optional. For the 450PS version only the brake pads Pagid with the part no. S8100R29001-RSL29 (front) in connection with part no. E2704 190 10 RSL19 (rear) marked VRM M2 and supplied by the organizer or its representative are to be used.

2.5 Steering

The steering is defined by the parts catalogue and must be installed without modification.

2.6 Suspension

The suspension was modified for use on a racetrack and is defined by the parts catalogue. Basically, it is not to be changed. The following points for tuning the suspension are an exception:

- Setting the compression and rebound rate of dampers in the screws for this purpose
- Checking and setting the air pressure in the damper
- Setting the track on the tie rod

- Setting the camber in the strut bearings on the front axle, as well as the eccentric screws on the rear axle
- Setting the ride height in the damper
- Setting the roll stabilisers at the intended junctures
- The roll stabiliser may be decommissioned. To do so, the entire roll stabiliser must be removed.

All components used must be listed in the parts catalogue and must be obtained from BMW AG. Springs, assister springs and bump stops are fixed. Changes to the components, for example, modifying the valves in the dampers, are expressly forbidden.

Only for the standard front springs, there will be an option to use the BMW 220 kilo version as stated in the catalogue.

All settings must remain within the specified tolerance.



LOWER WISHBONE

Links of the front axle



LOWER wishbone



top wishbone

Links of the rear axle

The damper must have the following measurements:

	Avant / Front	Arrière / Rear
Type Type	HYDRAULIC-GAS	HYDRAULIC-GAS
Marque e Make	ZF RACE	ZF RACE
Numéro de série type Typical series number	8 324 125	8 234 126
Réservoir de gaz Gas tank	INTERNAL	INTERNAL
Volume du réservoir de gaz Volume of gas tank	~44 cm ³	~64 cm ³
Longueur ouverte maximale Maximum open length	458.2 mm ±2 DAMPER BODY TO UNIBAL CENTER	475.5 mm ±2 DAMPER BODY TO UNIBAL CENTER
Longueur fermée minimale Minimum closed length	354.2 mm ±2 DAMPER BODY TO UNIBAL CENTER	368.5 mm ±2 DAMPER BODY TO UNIBAL CENTER
		

2.7 Wheels (Flange + Rim) and Tyres

Only the labelled Hankook tyres with the dimensions 280/660-18 (slick) and 260/660-18 (wet) may be used for the VRM BMW M2 Cup. The parts catalogue specifies a slick tyre and a wet-weather tyre. The tyres must be obtained from Racetyres B.V. in Zandvoort and will be labelled before they are issued.

Racetyres B.V.

Leeuwerikenstraat 16 F2
2042 CS Zandvoort - Netherlands
Contact : Jan Paul van Dongen
Mobile : 0031 6 555 03 961
Email : info@racetyres.nl

There is a limit of 8 new slick tyres per event used for the qualification and both races. Before the qualification a Tyre Note has to be submitted to the scrutineers with the registration numbers of maximum 8 new slicks and two used slick tyres. The number of labelled Hankook tyres for free practices and private tests during the events are free. Furthermore, the number of wet-weather tyres is not restricted.

The heating of tyres before qualifying and races is not permitted.

It is not permitted to treat the tyres with chemicals. Exceptions to this rule are soapy water to clean them and the lubricant for assembly.

The scrutineer may take tyre samples at any point during the event. These samples will undergo a chemical analysis and be compared with a reference tyre by the tyre partner.

Except for the removal on pickup, the tyres must not be processed mechanically. Cutting or re-cutting tread patterns is expressly prohibited.

Rims with a dimension of 10Jx18, as outlined in the parts catalogue, must be used. These rims must be obtained from BMW AG.

The type and make of the wheel nuts is free.

2.8 Bodywork and Dimensions

a) External Bodywork (Including Windows)

The organiser regulates the window stickers. As outlined in the parts catalogue and the user manual, the windows on the driver's door and the passenger door are to have a safety film stuck to them. It is not permitted to cut additional openings out of the windows to ventilate the cockpit.

In general it is not permitted to close or mask openings or joins. In the event of provisional repairs during the event, joins or openings in the area of damage may be covered, provided this is necessary due to a lack of time. The scrutineer will decide whether the repair measures are permitted.

If unusually low temperatures make it necessary to close the air vents, the scrutineer must approve this explicitly.

Compared with the series vehicle, the wheel arch was extended and the front of the vehicle was reinforced.

The windscreen may be covered with a clear, non-tinted tear off film for protection. These films must not be labelled. The films must not have any air bubbles that interfere with the driver's field of vision.

b) Cockpit

No individual ventilation tubes are permitted. A drinking device may be installed, provided that it is permanently attached and the holder can withstand acceleration forces of up to 25G. The scrutineer is responsible for assessing whether he or she feels that the holder is sufficient.

The pedals must not be changed. The only exception is the attachment of a film with increased friction.

The seat, seat consoles and belts must correspond to the parts catalogue and are only to be obtained from BMW AG. The standard steering column adjustment is retained. In the interior all covers are to be used as outlined in the parts catalogue.

If the entrant registers a driver who is not able to use the seat defined in the parts catalogue safely due to his or her physical conditions, the series' organiser can approve a different seat and related console upon receiving an individual written application.

A seat test supervised by the responsible scrutineer must take place to demonstrate that the seat specified in the parts catalogue cannot be used. Approval will be given only if the scrutineer deems there to be a safety risk.

This approval is specific to a driver and applies only if the relevant driver participates in the event. The alternative seat used, and the console must conform with Article 253, Appendix J and must be presented during scrutineering.

The request can be informal, but must contain the driver's name and licence number, as well as the manufacturer and number of the requested seat variant and console.

c) Additional Accessories

Accessory components from the parts catalogue may be installed and can be offset by the ballast mentioned in Part 2 Art. 1.6 of these regulations.

d) Track Width

Track width front: min. 1543mm max. 1593mm. Track width rear: min. 1597mm max 1647mm.

Measurement instructions:

The car is measured in the reference area. For information on the reference area, refer to TR

Art. 1.5.1. The tyre pressure may be raised to the reference pressure (2.4bar FA; 2.3bar RA) for the measurement.

A right angle (90°) is placed on the ground perpendicular under the centre of the axle, outside and inside the tires and positioned to the respective sidewall of the tyre. These four positions are marked on the ground. The distance between the markings (outside to outside and inside to inside) will be measured, added and halved. The result is the track width.

2.9 Aerodynamic Devices

The following aerodynamic devices are mandatory, as defined in the part catalogue:

- Front splitter
- Rear wing

The position of the rear wing is defined as follows:

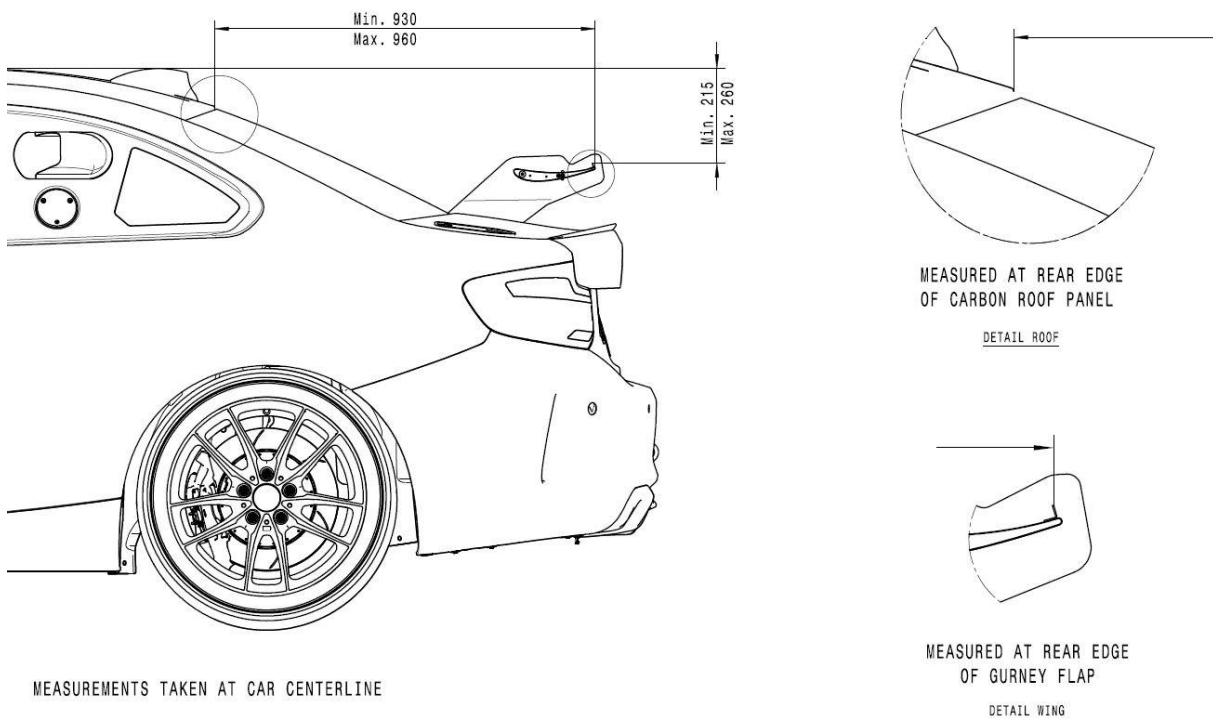

2.10 Electrical Equipment

As dictated in the parts catalogue, the already build in logger AIM MXG 1.2 is to be used.

The data from the data logger is used by the series organiser to check the conformity of the cup cars. The data from the individual participants can be made public to all other competitors. Among other things, the throttle valve position, engine speed, driving speed, gear, boost, air charge temperature, lambda, firing angle and quantity of fuel injected are recorded and checked by the series' organiser. Deviations in these values outside of the tolerance defined by the series' organiser will be treated as attempted manipulation.

The participant is responsible for ensuring that the sessions (all laps completed) are recorded properly and that the data logger functions flawlessly. Should the logger itself, or part of the system (sensors, cable, etc.) be damaged or there be any doubt that it is working correctly, the series organiser must be informed in writing immediately.

If the data on the memory card no longer exist or is incomplete, can result in a penalty.

Repairs to the wiring harness may only be made with the approval of the technical commissioner.

Furthermore, participants are allowed to either connect a camera to the data logger or attach a separate camera in the car. The camera and holder of the camera must be shown to the scrutineer. The participant is obliged to provide VRM with the recordings when requested. VRM reserves the right to withhold recordings. The recordings should be used, among other things, to analyse crashes, show driving mistakes committed by other participants, for preventative purposes, and support the organisers in their decision making.

The entrant is also permitted to connect a system for recording data to one of these interfaces. The 12V interface prescribed for this purpose in the user manual must be used for the power supply.

For races, in which it is permitted to illuminate the car number, this may be carried out by the entrant. The 12V interface provided for this purpose should be used for the power supply.

Should the participants not comply with the aforementioned regulations, it may result in a penalty:

<u>Breach</u>	<u>Penalty</u>
Qualifying: Data on memory card not available or only partially available.	1 minute penalty, to be added to the fastest qualifying lap.
Race: Data on memory card not available or only partially available.	5 minute penalty added to total race time.

The Stewards may at their own discretion hand out a higher or lower penalty to the mentioned assessment fine.

2.11 Fuel Circuit

Defined in the parts catalogue and must be installed without modification.

A cable tie may be installed at the fuel tank cap (filler neck) for better handling due to the use of fire-proofed gloves.

The maximum fuel volume is restricted to 84 litres with the standard fuel tank. It is permitted to install the official BMW 120 litre endurance fuel tank. The participant is responsible to adjust the fuel volume for the official BMW 120 litre endurance fuel tank by means of a displacement body. To examine the maximum volume of the tank one must empty the tank completely in front of the acceptance committee and then refuel the tank. The refuelling may not exceed 84 litres.

2.12 Lubrication System

The lubrication system oils, fats, coolants and brake fluids) are defined in the parts catalogue, except from the engine oil.

It is allowed to use engine oils according to the following specification:

- BMW Longlife 01
- BMW Longlife 01 FE
- BMW Longlife 04
- BMW Longlife 12 FE

Upon request from the scrutineer or the series organizer, the participant / applicant has to promptly provide all information in written form (type, name, specification, and manufacturer) from the used utilities.

2.13 Data Transmission

Apart from the following exceptions, no data transmission between the vehicle and the environment is permitted:

- Radio communication
- TV cameras stipulated by the organiser
- Marshalling system stipulated by the organiser
- GPS Auge
- Transponder for measuring noise
- Transponder for timekeeping
- Lap trigger

No telemetry systems are permitted

If the organiser stipulates additional systems that involve the transmission of data, this must be approved by the scrutineer.

2.14 Other

(a) The following systems may be additionally installed in the vehicle:

- Tyre pressure check (sensors in the rims and antennae)
- Lap trigger
- GPS sensor
- Transponder for measuring noise
- Transponder for timekeeping, type AMB-Mylaps **(mandatory)**
- Potentiometer to determine the wheel stroke
- GPS Auge
- Temperature sensor for differential gear
- Temperature sensor for the brakes

If the organiser stipulates the assembly of additional systems in the vehicle, this must be approved by the scrutineer.

A system for monitoring tyre pressure using sensors and related antennae is permitted. As outlined in Article 1.11, valves that regulate pressure are not permitted.

(b) Control Units and Software Versions

Software and hardware for the control electronics can be checked by the series' organiser or the scrutineer at any time and must always conform with the current status specified in the user manual. If this is not the case this will automatically be reported to the Stewards and the series' organiser.

The series' organiser is permitted to update or replace the software version or the hardware of the control units at any time. The entrant must not overwrite or change any database or programme version in the control units.

(c) Radio System & Cameras

A radio system including antenna may be installed in the vehicle. The 12V interface stated in the user manual must be used for the power supply. Only if permitted by the organiser, cameras may be installed and connected with the entrant's own data logging system. The 12V interface stated in the user manual, or a stand-alone battery supply must be used for the power supply.

Radios and cameras must be permanently attached and the holders must withstand acceleration forces of up to 25G. The scrutineer is responsible for assessing whether he or she feels that the holder used is sufficient.

(d) Special Installations

As far as an approval / release from the RACB, the event organizer and the series organizer, as well as a RACB technical passport with relevant listing is available then a conversion kit for physically incapacitated may be installed.

The participant needs to request a National technical Passport at least 2 weeks before his registration to the first race he will attend (Passport is available on RACB website). This document needs to accompany the car during every meeting.

The RACB technical passport incl. all approvals needs to be handed out at the scrutineering. It should be noted that the clearance is relevant to the event and is only allowed with the related vehicle in accordance with the nominated driver.

Technical comments can be noted on this document.

The absence of this document during the technical check or the deliberate falsification of this document will be considered as fraud and can be punished with a financial penalty of € 150.

Part 3 Attachments / Drawings

Attachment 1: Advertising and Labelling on the Vehicle in accordance with the Series Regulations

The following areas are reserved for the series' organiser and are not available to the participant (Part 1, Art. 16, Part 2, Art. 1.09)..

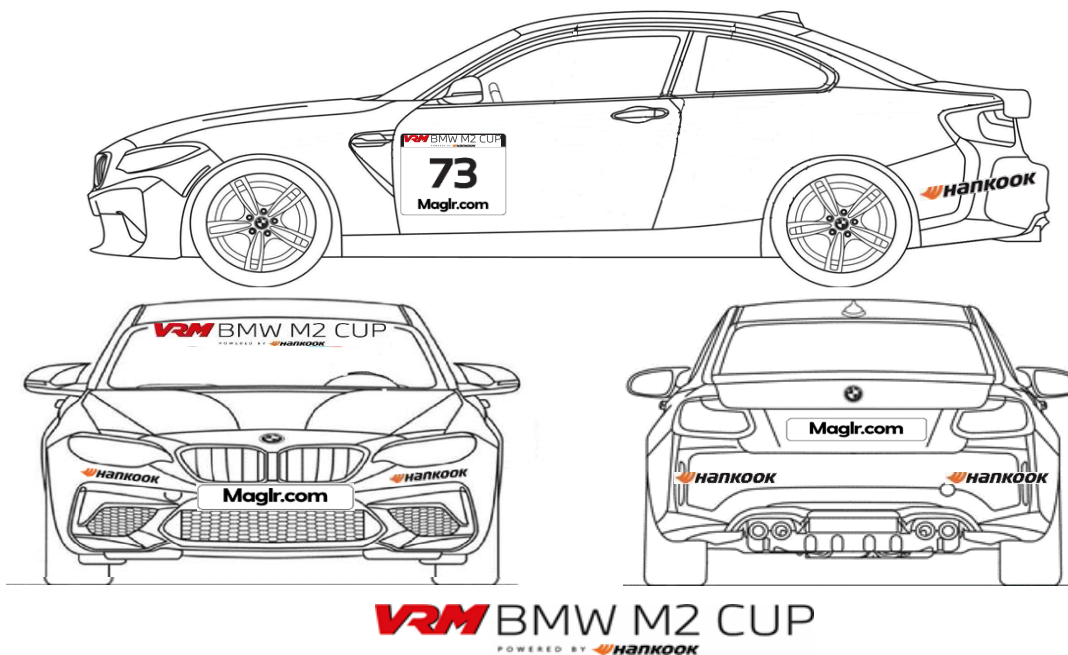

No.	Area	
1	Front bumper.corner right / left	HANKOOK
2	Rear bumper / corner right / left	HANKOOK
3	Front and rear licence plate	VRM
4	Front windscreen streamer	VRM
5	Start number sticker left - right	VRM
5	Side skirts right / left	VRM