



BELCAR SKYLIMIT SPRINT CUP
TECHNICAL REGULATIONS 2021



PAGINA INDEX

Art 1.	DEFINITION – DESCRIPTION	2
Art 2.	REGULATIONS	2
Art 3.	BODYWORK AND OTHER EXTERNAL DIMENSIONS	6
Art. 4	WEIGHT	14
Art. 5	ENGINE	16
Art 6.	FUEL LINES, FUEL PUMPS AND FUEL TANKS	19
Art 7.	LUBRICATION SYSTEM	22
Art 8.	ELECTRICAL EQUIPMENT	23
Art 9.	TRANSMISSION	25
Art 10.	SUSPENSION AND STEERING MECHANISM	26
Art 11.	BRAKES	28
Art 12.	WHEELS AND TIRES	30
Art 13.	COCKPIT	31
Art 14.	SAFETY EQUIPMENT	33
Art 15.	SAFETY STRUCTURE	36
Art 16.	FUEL	37
Art 17.	CURRENT TEXT	37
Art 18.	APPROVAL	37



VZW Terlamen is the promoter of the Belcar Sprint Championship 2021 in accordance with the regulations of the International Sporting Code of the FIA, the National Sporting Code of RACB sport, the current regulation and possibly the additional (special) regulation, to which all participants must submit through their participation. Every member of a participating team must take note of the full content of the current regulation.

Art. 1 DEFINITION – DESCRIPTION

A race car for the Belcar Sprint Championship is defined by RACB Sport, in agreement with the promoter. This car is suitable for sporting purposes and has at least one exit on each side. The base model has to be homologated for the public road or homologated for races by the FIA or by an ASN.

T	GT	Applicable text
x		Applicable text for Touring cars
	x	Applicable text for GT cars

Art. 2 REGULATIONS

2.1 Role of RACB Sport

The technical regulations of the Belcar Skylimit Sprint Cup 2021 are issued by RACB Sport, in agreement with the promoter.

2.2 Allowed modifications

Every construction or modification not authorised by the Technical Regulations Belcar Sprint Championship is expressly prohibited. An authorised modification cannot lead to an unauthorised modification.

2.3 Allowed cars

Belcar Skylimit Sprint Cup 2021 is only open to cars based on an FIA homologated road legal car of the type Tourism (T) or GT.

Participation in the Belcar Skylimit Sprint Cup is reserved for vehicles that are conform to the technical regulations of the Belcar Skylimit Sprint Cup and are divided into :

- Class 1
- Class 2
- Class 3
- Class 4
- Class 5

In case of contradictions between the technical regulations of the « Belcar Skylimit Sprint Cup » and any other technical regulations (from monobrand cup championships,...), the regulations of the « Belcar Skylimit Sprint Cup » will be followed.

Cars not following these requirements may be exceptionally accepted by RACB in agreement with the promoter on the base of a technical file. RACB sport will determine in which class the car will be registered.



The RACB sport, in agreement with the promoter, reserves the right to take any action to slow down the cars if needed.

2.4 Not allowed cars

GT1, GT2, GT3 cars are not allowed.

Silhouette cars or similar are not allowed.

Cars from FIA Sportscars, DTM >2000, Be Trophy/VW Fun Cup, 2CV, Legend Cars or similar/equivalent categories in other championships and that have not been homologated, are not allowed.

2.5 Classes

Class 1 : All cars	less than	1000cc		
Class 2 : All cars	from	1001cc	to	1800cc
Class 3 : All cars	from	1801cc	to	2500cc
Class 4 : Tourism cars	from	2501cc		
Class 5 : GT cars	from	2501cc	to	3600cc

Additional requirements:

Class 4 : cars with a turbo engine needs to be at least 5 years old.

Class 5 : Porsche 911 cars are allowed until model 996 (997 and subsequent models are not allowed).

Cylinder capacities corrections

The nominal cylinder capacity is multiplied by :

x1.7 for supercharged/turbocharged petrol engines

x1.5 for supercharged/turbocharged diesel engines

x1.8 for rotary engines

The car must pass into the class corresponding to the fictive volume thus obtained.

The car must be treated in all respects as if its cylinder capacity thus increased were its real capacity.

This is particularly the case for assigning the car to its cylinder capacity class, its interior dimensions, its minimum number of places, its minimum weight, etc.

2.4 Dating of the regulation

This Technical Regulation will immediately enter into force (see date of approval at the bottom of this document). From that date, it replaces and cancels all prior Technical Regulations.

A change to the regulation concerning safety, issued by the FIA, will be applicable starting from the next meeting.

2.5 Passport of the vehicle and technical race passport

All competitors must request a National Technical Passport for their cars.

This passport must be requested by the participant at least 2 weeks before his registration to the first race he will attend. All information needed to request the passport are available on RACB Sport website.

This document needs to accompany the car during every meeting. During the technical check, this document needs to be presented. Technical comments can be noted on this document. Car must be compliant to the information given in the Passport at any moment of the competition.

If the passport of a vehicle is not or incompletely or incorrectly filled in, the car can be refused for the meeting.

If, during the season, a competitor wishes to present a change to the technical data included in the passport of the vehicle, he needs to do so in a written way or by email to RACB Sport, and this at least 14 calendar days before the start of the meeting.

RACB Sport reserves the right to accept or deny this change if it does not answer to the spirit of the regulation and if it excessively increases the performances and/or preparation and exploitation costs of the vehicle, even if not explicitly forbidden.

The absence of this document during the technical check or the deliberate falsification of this document will be considered as fraud and can be punished with a financial penalty of € 150.

2.6 Conformity of the regulations

During a meeting, the competitor must ensure that his car meets all regulations that are applicable to his car. (sporting regulation, technical regulation, homologation form, technical race passport, etc.)

To determine the conformity of the car, both participant and RACB Sport can appeal to the technical data of the constructor, as well as to other official data of the sportive authority.

Requests for new homologations or extension of homologations need to be transmitted to RACB Sport.

Every modification that does not meet the spirit of the regulation, even if not explicitly forbidden, but that could excessively raise the reparation costs of a car, is without prior warning forbidden by the Technical Commission of RACB Sport.

A car of which the construction and/or modification can include risks, cannot sign up nor participate and this without prior warning.

A car of which the construction can bring possible dangers, can be excluded by the College of Sports Commissioners of RACB Sport, on advice of the Technical Commission.

2.7 General statements

Articles 251, 252, 253, and 277 of current Annex J of the FIA remain applicable, but the articles of the current regulation are decisive.

Every bolt, nut or screw of the car can be replaced by another bolt, nut or screw on the condition that it is of the same material family, the same diameter or bigger than the original part and contains a blocking method (ring, counter nut).

Materials

For the mechanical parts, chemical or thermal treatments are allowed, on the condition that the weight and dimensions are maintained as mentioned on the homologation form or on the technical document of RACB Sport.

The following materials are forbidden : magnesium (except for the rims), ceramic and titanium (only if original), except as stated in art. 5.2.1. of this regulation.

The use of composition materials is allowed within the limits of this regulation.

The used material for the bodywork elements (trunk lid and engine compartment, bumpers, doors and wings) is limited to glass fibre, but in case an element is being replaced, it needs to be fixed at least as solid as the original element.

2.8 Telemetry

Any form of wireless data transmission between the vehicle and any person and/or equipment is prohibited while the car is on the track.

This definition does not include:

- Voice radio communications between the driver and his/her team
- Transponder from the official timekeeping, and
- Automatic timing recording.

None of the previously mentioned transmission data may in any way be connected with any other system of the car (except for an independent cable to the battery only).

2.9 Electronics

Any traction control (TC) system is forbidden, except if it is standard on the base vehicle or if the vehicle has been homologated with this system.

If the engine control unit has a traction control system, it cannot be activated. It is the task of the participant to show that this function has not been activated and has been decommissioned.

The RACB Sport can impose the rule that a vehicle can only be equipped with one sensor measuring the speed of the wheel revolution.

2.10 Technical check

Before the start of a meeting, the technical scrutineers will indicate the place for the check of the height of the car and the weighing. It is the task of the participant to inform himself about the place of the check.

Tyre pressure must be set at 1.5 bar for the technical checks.

Within the time period of the check, imposed by the organisers, the participant has the possibility to ensure himself of the conformity of his car, using the equipment of the official check, at the place of the official check.

Art 3. BODYWORK AND OTHER EXTERNAL DIMENSIONS

3.1 Dimensions

T	GT	Dimensions
x	x	<p>The chassis cannot be modified unless permitted by the present regulations. All chassis modifications including the removal of unused supports have to be certified in the Technical Form.</p> <p>The maximum length needs to respect the length of the production model, with an authorised deviation of 25 mm and with the exception of the regulations in article 3.4.3.</p> <p>The width of the car must be conform to article 3.5.1.</p> <p>The bodywork of homologated race cars or monobrand cup cars must be in conformity with the homologation form and the cup regulations.</p>

3.2 Doors

T	GT	Doors
x	x	The dimensions and functions of the original car doors need to be preserved. If a door has been replaced by a door in glass fibre, the safety cage needs to be equipped with at least a lateral protection 'X' (drawing 253-9) in conformity with the valid FIA regulations of Article 253-8.
x	x	It is mandatory that all doors can be opened without any tool from the outside of the car, as well as from the inside for the front doors.
x	x	<p>It is allowed to change the original hinges and latches of the doors with the sole purpose of offering the pilot a quicker evacuation in case of an accident. It is mandatory that the front doors can be opened without any tool from the inside as well as from the outside of the car.</p> <p>The interior lining of the doors cannot be removed. The interior lining can remain original or can be made of metal plates with a minimum thickness of 0,5 mm or be made of carbon fibre with a minimum thickness of 1 mm or be made of another solid material with a minimum thickness of 2 mm.</p>

3.3 Windshield and windows / screens

T	GT	Windshield and windows / screens
x	x	<p>The shape of the windscreen must be that of the windscreen of the reference vehicle. The windscreen must be of one-piece laminated glass and road legal, or of a polycarbonate or PMMA ensuring the same transparency as the original glass. If of polycarbonate or PMMA, the thickness must not be less than 4.75 mm. Tinted glass screens are only permitted if they are original for this car.</p>

		<p>A windscreen with integrated demisting system is allowed provided it complies with the other requirements of this article.</p> <p>Windscreens which are damaged to such an extent that visibility is seriously impaired or that there is a likelihood of their breaking further during the competition will be rejected. The addition of a maximum of 6 protective transparent and colourless films on its external face is permitted (maximum total thickness of 400 microns).</p> <p>Stickers and spraying are not allowed, except those authorised by the FIA Sporting Code Article 15.7 and Belcar Skylimit Sprint Cup Sporting Regulations.</p> <p>Additional safety fastenings for the windscreen and the side windows may be fitted provided they do not improve the aerodynamic qualities of the car.</p>
x	x	An efficient windscreen demisting system is mandatory
x	x	<p><u>Side and rear windows</u></p> <p>Glass can be replaced with polycarbonate or PMMA ensuring the same transparency as the original glass (minimum thickness 4.5 mm).</p> <p>In case glass windows (side and/or rear) are used, the internal face of the windows must be covered with a transparent and colourless plastic safety film with a maximum thickness of 0.1mm in order to avoid the shattering and spraying of glass in the event of an accident. It must be fitted in a manner that facilitates checking.</p> <p>This same safety film must be fitted on glass rear-view mirrors.</p> <p>A sliding window in the side windows of the driver's and co-driver's doors can be fitted. The opening must be a minimum of 130 mm x 130 mm and a maximum of 150 mm x 150 mm.</p> <p>A frame may be added to the door if it is originally frameless.</p> <p>In the case of cars with 4 or 5 doors, the lift mechanism for the rear windows may be replaced with a device that locks the rear windows in the closed position.</p> <p>The view in all directions needs to be preserved at all times. It must be possible for a person situated 5m from the car to see the driver as well as the content and complete interior of the. The side windows need to remain clear.</p> <p>Stickers and spraying are not allowed on the front side windows.</p> <p>The names of the drivers, the national flag of the drivers and possibly the mandatory advertising by the organiser can be applied on the rear side windows.</p> <p>Darkening of the rear window (colour film or obscuration band) is not allowed.</p> <p>The windows of the car need to remain free of publicity, with the exception of a band/film with a maximum width of 10 cm on the upper part of the windshield and, if the rearward visibility is preserved, a band/film with a maximum width of 8 cm on the rear window.</p> <p>On the windshield, only the by the promoter obliged publicity (banner) and a miniaturised race number (far right corner with a height of 100 mm) can be applied.</p> <p>All side windows need to remain closed for $\frac{3}{4}$ during trainings and races. The installation of a safety net at the pilot's side is recommended.</p>

		<p><u>Cockpit ventilation</u></p> <p>To extract air from the cockpit, the rear window may have a maximum of 5 circular holes with a maximum diameter of 50 mm each. A cut-out of a maximum surface of 25 cm² is authorised in each rear-view mirror.</p> <p>A scoop may be fitted to each door window, provided that it complies with the following points :</p> <ul style="list-style-type: none"> - It must not exceed the perimeter of the window, must have a maximum height of 150 mm and must not protrude more than 50 mm over the window's surface; - It must be made from the same material as the window or from translucent polycarbonate if the window is made from glass, and must be able to be closed by a shutter made from the same material as the window; - It must not obstruct the driver's rearward view. <p>Air ducts fed by the scoops are authorised inside the cockpit on condition that they reduce neither the visibility nor the safety of the driver.</p> <p>Each rear side window may be partly opened to a maximum of 30 mm at its rear extremity, or may have a circular opening with a maximum diameter of 50 mm.</p> <p><u>Nets</u></p> <p>The use of nets affixed to the safety cage is mandatory. These nets must have the following characteristics:</p> <ul style="list-style-type: none"> - Minimum width of the strips 19 mm - Minimum size of the meshes 25 x 25 mm - Maximum size of the meshes 60 x 60 mm <p>and must close up the window opening to the centre of the steering wheel.</p> <p>The net must consist of woven strips made of fireproof material and the crossing points need to be stitched together. The net cannot be of a provisional nature.</p> <p>Racing nets approved according to FIA Standard 8863-2013 (Technical list n°48) on both sides of the driver are recommended. They must be installed in accordance with the installation specifications published by the FIA.</p>
--	--	--

3.4 Bodywork

T	GT	Bodywork
x	x	Bodywork: All entirely hung parts of the car that are touched by the outside air stream, with the exception of parts that are undoubtedly linked to the mechanical functioning of the engine, the transmission and the suspension. Every air intake is considered to be part of the bodywork.
x	x	Under no circumstances, is it allowed to modify the chassis. In relation to the wheelbase, the chassis must maintain its original position. Modifications to the chassis are only allowed for the installation of a safety cage, providing that they comply with the regulations about safety cages, art. 15.1.

x	x	At any given moment during the use of the car on the racetrack, the bodywork parts need to remain in place.
x	x	No part of the car and no elements hanging from the car, can be found within 55 mm of the ground. For homologated race cars, or monobrand cup cars, ride height must be compliant with the homologation form and the regulations of the cup.
x	x	The ride height must be adjustable only with the use of tools and when the car is immobile.
x	x	If, during the meeting, the car was involved in an accident, the conformity of these values will be evaluated by the Technical Commission.
x	x	RACB Sport, in agreement with the promoter, reserves the right to adapt the ground clearance of a car as part of a balance of performance process.

3.4.1 « Flat » bottom

T	GT	« flat » bottom
x	x	The use of a flat bottom is allowed only: <ul style="list-style-type: none"> - If homologated with the car - If sold by the original car manufacturer for this model of vehicle - If built according to the following specification : It must consist solely of multiplex wood (incl. betonplex) with a minimum thickness of 4 mm.
x	x	If no flat bottom is installed, the bottom of the car cannot be modified and must remain identical to the road legal base model of the car, with the exception of holes that have the sole purpose of cooling the mechanical parts.
x	x	In top-down view, from a vertical projection, the flat bottom cannot be visible.
x	x	Skirts (Jupes) are not allowed. Every device or construction built completely or partially between the underbody of the car and the ground is strictly forbidden.
x	x	Between the vertical and transversal surface formed at the front of the complete front wheels and at least the wheel axle of the rear wheels, all the bodywork parts that are directly visible on the bottom of the car, with the exception of the wheel arches and the exhaust pipe, need to be described in a plan. This plan, also called Flat Bottom or Reference Surface, needs to be a unified, solid, hard and rigid surface (no level of freedom towards the unity chassis/bodywork). The perimeter of the surface described by these parts can be round up to a radius of maximum 25mm. In order to defeat possible manufacture difficulties, a tolerance of +/- 5 mm to this surface is allowed. No hanging part of the car is allowed under the flat bottom and no air flow may run over it. No air flow with aerodynamical effect is allowed between the bodywork and the flat bottom. The channelled air flows towards the air intakes or coming from the air outlets that run above any part of the flat bottom cannot result in a positive or negative air pressure. The part of the flat bottom between the axle of the front wheels and the vertical and transverse surface formed at the front of the complete front wheels needs to have a minimum width of 1000mm.

3.4.2 « Rear Diffuser »

T	GT	« Rear Diffuser »
x	x	<p>The use of a rear diffuser is allowed only:</p> <ul style="list-style-type: none"> - If homologated with the car - If sold by the original car manufacturer for this model of vehicle - If built according to the following specification : <p>The installation of a dive plane at the end of the flat bottom is allowed:</p> <ul style="list-style-type: none"> ▪ Between the vertical parts formed by the inner surface of the rear wheels. ▪ Between the rearmost point of the flat bottom and the vertical part formed by the extreme point of the bodywork. <p>No part of the diffuser is allowed at more than 215 mm off the ground. Vertical flat shaped wedges are allowed if they remain parallel with the longitudinal centre line of the car.</p> <p>The maximum height of a gurney, installed on the diffuser, is 10 mm.</p> <p>Any modification to the rear bumper is prohibited.</p>

3.4.3 Front bottom panel

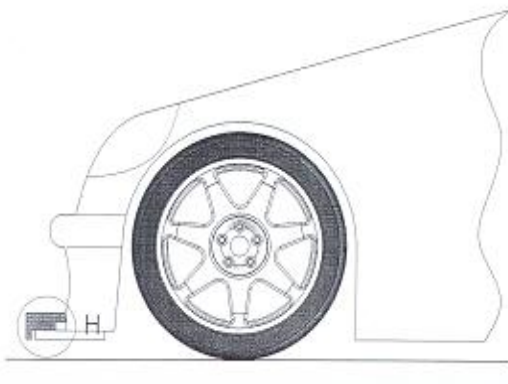
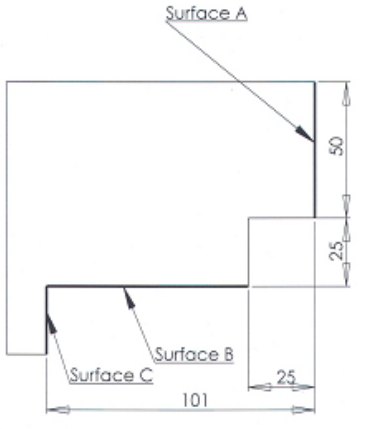
T	GT	Front bottom panel – Spoiler - Splitter
x	x	<p>The use of a front bottom panel between the front bumper and the front of the flat bottom is allowed only:</p> <ul style="list-style-type: none"> - If homologated with the car - If sold by the original car manufacturer for this model of vehicle - If built according to the following specification : <p>The bottom panel must be flat or homologated.</p>
x	x	The original front overhang can be enlarged by adding a spoiler (max. thickness: 30 mm).
x	x	<p>The spoiler needs to remain within range of Template B, as described by the drawing below, and needs to respect Template A.</p> <div style="display: flex; justify-content: space-around; align-items: flex-end;"> <div style="text-align: center;">  <p>Template A</p> </div> <div style="text-align: center;">  </div> </div>

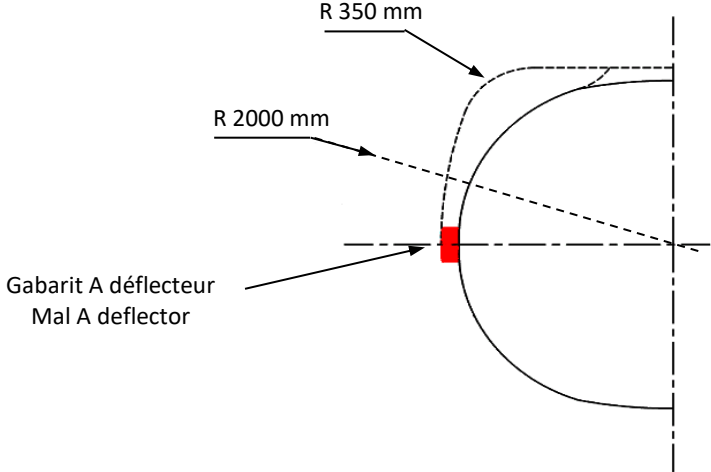
		<p>When Template A touches at least 1 part of the bodywork at a maximum of 25 cm of the longitudinal axis of the car on its surface A, and with the whole surface B in contact with the spoiler, not a single part of the spoiler can touch Surface C (dimensions in mm).</p>  <p>Template B</p> <p>In the front, every change to the original form of the bumpers cannot aim at extending the length of the spoiler.</p> <p>Drawbars are allowed, but it needs to be possible to dismount them before every technical check.</p>
<p>x</p>	<p>x</p>	<p>In frontal view, the spoiler cannot exceed the width of the race car, measured at the front wheel axle.</p> <p>A maximum of 2 aero dynamic elements can be added above the spoiler, on both sides of the car.</p> <p>These must be located:</p> <ul style="list-style-type: none"> ▪ At the front of the vertical plane, tangent to the complete wheels. ▪ Within the perimeter of the spoiler, seen from above. ▪ With a constant thickness. ▪ Outside the original front of the car. ▪ Maximum 180 mm above the flat bottom for GT cars ▪ Maximum 350 mm above the flat bottom for Touring cars. <p>They cannot:</p> <ul style="list-style-type: none"> ▪ Cover the headlights. ▪ Be wider than 250 mm. ▪
<p>x</p>	<p>x</p>	<p>If the car has a splitter that does not meet the mentioned specifications, it needs to be approved by RACB Sport.</p>

3.4.4 Openings in the « flat bottom » and in the « rear diffuser »

T	GT	Openings in the « flat bottom » and « rear diffuser »
x	x	<p>The sole openings allowed in the 'flat bottom' and 'rear diffuser' are:</p> <ul style="list-style-type: none"> ▪ Cut-outs that serve the wheel movements. ▪ Hatches for maintenance purposes. ▪ Entry for pneumatic jacks. ▪ Exit for the overflow pipes of gasoline + relief valves oil ▪ Opening or recess for the evacuation of exhaust warmth ▪ Maximum 4 'NACA' air circulation holes for cooling, of which the total horizontal surface cannot exceed 360 cm²

3.4.5 Structure of the bodywork

T	GT	Structure of the bodywork
x	x	<p>The bodywork must, in a vertical projection seen from above, cover all mechanical elements, with the exception of the bottom half of the complete wheels.</p> <p>Seen from the side and to the front, no part of an air intake can be located passed the highest point of the windshield.</p>
x	x	<p>The car cannot have any protruding parts, sharp edges or sides. When the car is in motion, every part of the bodywork, aerodynamic parts included, must be firmly fixed to the chassis/bodywork of the car. These parts cannot have any level of freedom and must remain firmly secured.</p>
x	x	<p>At least two additional safety fasteners must be fitted for each of the bonnet and boot lids.</p> <p>The original bonnet and boot locking mechanisms must be rendered inoperative or removed. If the original hinges are preserved, at least two additional safety fasteners must be fitted for each of the bonnet and boot lids.</p> <p>If the original hinges of the hood and/or trunk lid are not preserved, safety fasteners need to be installed in all 4 corners.</p> <p>All safety fasteners need to be clearly marked with contrasting colours.</p>
x	x	<p>All bodywork seals in the vicinity of gasoline connections need to be designed in a way that leaks of gasoline to the engine compartment or the cockpit are avoided.</p>

3.5 Additional changes to the bodywork and chassis

3.5.1 Maximum width

T	GT	Maximum width
x	x	<p>The width of the car can be increased by 50 mm each side (front and rear wheel arches measurement) compared to the road legal base car model.</p> <p>The maximum width of the vehicle (rear-view mirrors not included) is 2000 mm, except if the homologated road legal base car is wider, in which case the original width must be kept.</p>

3.5.2 Rear wing

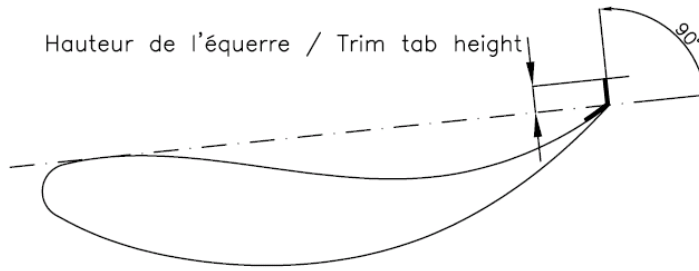
T	GT	Rear wing
x	x	The installation of a rear wing is allowed. It can replace the original wing, but adding an additional rear wing is not allowed.
x	x	<p>The complete wing unit cannot form the highest point of the bodywork (gurney included), except if original or part of the homologation. If the car has an air intake through the roof, the intake will not be considered while determining the highest point of the roof. The highest and most accessible point will be used for the measuring.</p> <p>The rear wing cannot be the most rearward point of the car unless it is part of the homologation of the car. Every change to or extension of the bodywork aimed at moving the wing to the back, is prohibited.</p>
x	x	The wing can only consist of one aerofoil section. Two flaps are prohibited.
x	x	<p>A Gurney is allowed, but there cannot be any airflow between the gurney and the wing surface. The trailing edge can have a maximum height of 25 mm, measured perpendicularly on the surface formed by the wing and needs to be firmly fixed over its complete length if it does not form an integral part of the wing.</p> 
x	x	<p><u>Dimensions</u></p> <p>The wing (endplates included) needs to fit in a volume with a maximum dimension of 520 mm (longitudinal and horizontal) x 150 mm (height) x 1700 mm (transversal).</p> <p>The length of the cord of the wing diameter can be maximum 400 mm.</p> <p>The wing cannot be the widest point of the car except if it is part of the homologation of the car.</p>
x	x	<p><u>Vertical wing supports</u></p> <p>Their surface needs to be flat and parallel to the longitudinal centre line of the car. They need to be distant at least 100 mm of the end plates and they need to be made out of metal (attachment included).</p> <p>Leading edge can be rounded off (with a constant radius) and trailing edge can be bevelled over 20 mm max.</p> <p><u>Endplates</u></p> <p>Their surface needs to be flat and parallel to the longitudinal centre line of the car and their minimum thickness is 10 mm. The edges need to be rounded off with a constant radius of minimum 5 mm, except in case of a specific homologated approval by RACB Sport.</p>

3.5.3 Bumpers

T	GT	Bumpers
x	x	The front and rear bumpers cannot be removed or reinforced and need to remain in place during the complete duration of the meeting. In vertical projection, as seen from above, the front and the back shape of the bumper need to have the same profile as the original version. No part of the bumper can be located outside this shape, except if it has been homologated by the FIA or RACB Sport.
x	x	The lateral parts can be connected to the fender in order to preserve the aspect of the original car.
x	x	It is allowed to close the openings in the bumpers made for additional lights if these are not installed.

3.5.4 Fenders

T	GT	Fenders (flanks)
x	x	<p>Cut-outs or openings in the front and rear fenders are only allowed, if:</p> <ul style="list-style-type: none"> ● The bodywork covers all mechanical elements in a vertical projection, as seen from above. ● Their height does not exceed the maximum height of the wheel opening. ● A safety measure needs to be installed at the cut-outs or openings in order to avoid projections to the back. <p>Adding 'dérives/flaps' is not allowed.</p>

3.5.5 Varia

T	GT	Varia
x	x	<p>Adaptions that are necessary for additional light supports and connections for refuelling are allowed.</p> <p>Additional lights cannot be installed beyond the most frontal point of the car.</p>

Art. 4 WEIGHT

4.1 Minimum weight

T	GT	Minimum weight
x	x	<p>This is the real weight of the car, with neither driver nor co-driver nor their equipment and with a maximum of one spare wheel.</p> <p>When two spare wheels are carried in the car, the second spare wheel must be removed before weighing.</p> <p>At no time during the competition may a car weigh less than this minimum weight.</p> <p>In case of a dispute during weighing, the full equipment of the driver and co-driver must be removed; this includes the helmet, but the headphones external to the helmet may be left in the car.</p> <p>In case of doubt, the Scrutineers may drain the tanks containing consumable liquids to check the weight.</p> <p>The use of ballast is permitted in the conditions provided for under Article 252-2.2 of the "General Prescriptions".</p>

x	x	<p><u>Minimum weight :</u></p> <table style="width: 100%; border-collapse: collapse;"> <tr> <td style="width: 30%;"></td> <td style="width: 10%; text-align: right;">up to</td> <td style="width: 20%;">1000 cm³</td> <td style="width: 40%; text-align: right;">670 kg</td> </tr> <tr> <td>over 1000 cm³</td> <td style="text-align: right;">and up to</td> <td>1400 cm³</td> <td style="text-align: right;">760 kg</td> </tr> <tr> <td>over 1400 cm³</td> <td style="text-align: right;">and up to</td> <td>1600 cm³</td> <td style="text-align: right;">850 kg</td> </tr> <tr> <td>over 1600 cm³</td> <td style="text-align: right;">and up to</td> <td>2000 cm³</td> <td style="text-align: right;">930 kg</td> </tr> <tr> <td>over 2000 cm³</td> <td style="text-align: right;">and up to</td> <td>2500 cm³</td> <td style="text-align: right;">1030 kg</td> </tr> <tr> <td>over 2500 cm³</td> <td style="text-align: right;">and up to</td> <td>3000 cm³</td> <td style="text-align: right;">1110 kg</td> </tr> <tr> <td>over 3000 cm³</td> <td style="text-align: right;">and up to</td> <td>3500 cm³</td> <td style="text-align: right;">1200 kg</td> </tr> <tr> <td>over 3500 cm³</td> <td style="text-align: right;">and up to</td> <td>4000 cm³</td> <td style="text-align: right;">1280 kg</td> </tr> <tr> <td>over 4000 cm³</td> <td style="text-align: right;">and up to</td> <td>4500 cm³</td> <td style="text-align: right;">1370 kg</td> </tr> <tr> <td>over 4500 cm³</td> <td style="text-align: right;">and up to</td> <td>5000 cm³</td> <td style="text-align: right;">1470 kg</td> </tr> <tr> <td>over 5000 cm³</td> <td style="text-align: right;">and up to</td> <td>5500 cm³</td> <td style="text-align: right;">1560 kg</td> </tr> <tr> <td>over 5500 cm³</td> <td></td> <td></td> <td style="text-align: right;">1650 kg</td> </tr> </table> <p>Homologated or monobrand cup cars must respect the minimum weight defined in their homologation form or in the cup regulations.</p>		up to	1000 cm ³	670 kg	over 1000 cm ³	and up to	1400 cm ³	760 kg	over 1400 cm ³	and up to	1600 cm ³	850 kg	over 1600 cm ³	and up to	2000 cm ³	930 kg	over 2000 cm ³	and up to	2500 cm ³	1030 kg	over 2500 cm ³	and up to	3000 cm ³	1110 kg	over 3000 cm ³	and up to	3500 cm ³	1200 kg	over 3500 cm ³	and up to	4000 cm ³	1280 kg	over 4000 cm ³	and up to	4500 cm ³	1370 kg	over 4500 cm ³	and up to	5000 cm ³	1470 kg	over 5000 cm ³	and up to	5500 cm ³	1560 kg	over 5500 cm ³			1650 kg
	up to	1000 cm ³	670 kg																																															
over 1000 cm ³	and up to	1400 cm ³	760 kg																																															
over 1400 cm ³	and up to	1600 cm ³	850 kg																																															
over 1600 cm ³	and up to	2000 cm ³	930 kg																																															
over 2000 cm ³	and up to	2500 cm ³	1030 kg																																															
over 2500 cm ³	and up to	3000 cm ³	1110 kg																																															
over 3000 cm ³	and up to	3500 cm ³	1200 kg																																															
over 3500 cm ³	and up to	4000 cm ³	1280 kg																																															
over 4000 cm ³	and up to	4500 cm ³	1370 kg																																															
over 4500 cm ³	and up to	5000 cm ³	1470 kg																																															
over 5000 cm ³	and up to	5500 cm ³	1560 kg																																															
over 5500 cm ³			1650 kg																																															

4.2 Balance of performance

T	GT	Balance
x	x	<p>RACB Sport, in agreement with the promoter, reserves the right to change the class and/or minimum weight of a car, to impose a restrictor or to use another measure or enacting term in order to optimise the equality of performances between the cars. If a change in class has been carried out, the transmission of the already given elements towards the new class can be imposed and this completely depending on the RACB Sport and the promoter.</p>

4.3 Ballast

T	GT	Ballast
x	x	<p>It is permitted to complete the weight of the car by one or several ballasts provided that they are strong and unitary blocks, fixed by means of tools with the possibility to fix seals, placed on the floor of the cockpit, visible and sealed by the scrutineers. The sealing will be requested by the team.</p> <p>The ballast will be attached using bolts of a quality 10.9 with a minimum diameter of 10 mm. In order to avoid the ripping out, a reinforcement plate of min. 40cm² and 3 mm thick will be installed under the bottom.</p> <p>Any movable ballast system is strictly forbidden.</p>

4.4 Weighing

T	GT	Weighing
x	x	<p>The weight can be controlled at any given moment during the meeting, except during the race itself.</p> <p>Adding any solid material or replacing a certain part with a heavier one is explicitly forbidden during a race.</p>

Art. 5 ENGINE

T	GT	Engine
x	x	The engine and its systems are free, on the condition that they meet the prescriptions in art. 5.1 to 5.6.
x	x	For homologated cars, the engine and its systems (including air intake, exhaust, fuel, lubrication, cooling, control, ignition) need to be in conformity with their homologation file. For monobrand cup cars, the engine and its systems (including air intake, exhaust, fuel, lubrication, cooling, control, ignition) need to be in conformity with the homologation file or Technical File, and the Cup regulation.

5.1 Type and position of the engine

T	GT	Type and position of the engine
x	x	The brand, the number of cylinders and the position of the engine need to remain original. It is allowed to replace the engine of a car by an engine of the same brand, with the same number of cylinders, same layout, and in the same position as the original.
x	x	Engines from the FIA group C, FIA group GT1, GT2, GT3, FIA group Sportscars and the Deutsche Tourenwagen Meisterschaft (DTM), or similar classes in other disciplines anywhere in the world, are not allowed.
x	x	The engine needs to be installed in the original engine compartment.

5.2 Changes to the engine

5.2.1 Materials

T	GT	Materials
x	x	<ul style="list-style-type: none"> ● The use of magnesium and titanium is not allowed, unless it was used in the original part. ● The use of ceramic or ceramic covered components is not allowed, unless the material was used in the original part. Exception: the exterior ceramic treatment of the exhaust system. ● The use of carbon or composite material is limited to the clutch plates, non-stressed cover plates or non-stressed pipes. ● However, it is allowed to use heat-treatment on certain parts, on the condition that it remains possible to, beyond doubt, show that the part comes from a production model.

5.2.2 Accelerator pedal, can only find something 275-13.5

T	GT	Accelerator pedal
x	x	Only a direct mechanical connection between the accelerator and the engine is allowed. If the original vehicle is equipped with a throttle system without mechanical connection, this system can be preserved, but not modified Any other throttle system without direct mechanical connection will be subject to prior approval by RACB Sport.

5.2.3 Various

T	GT	Various
x	x	<ul style="list-style-type: none"> ● In the intake system, only throttle valves are allowed. Slide throttle valves and tube throttle valves are prohibited. ● Variable length or volume intake system are prohibited. ● Ignition is free.
x	x	<ul style="list-style-type: none"> ● It must be possible to identify the flywheel as an original element. However, it can be lightened and/or balanced.

5.2.4 Engine Control Unit (ECU)

T	GT	Various
x	x	The ECU is free for atmospheric engines, as is the rev limiter.
x	x	The ECU is free for supercharged engines. Under no circumstances, can the pressure of the supercharger be changed while driving.
x	x	For homologated cars, the ECU needs to be in conformity with their homologation file. For monobrand cup cars, the ECU needs to be in conformity with the homologation file or Technical File, and the Cup regulation.
x	x	The principle of injection, number and installation, that controls the dosage of the engine's fuel, needs to be preserved.
x	x	The ECU cannot include any traction control system.

5.3 Atmospheric/Normally aspirated engines

T	GT	Atmospheric engines cylinder capacity
x		The total cylinder capacity of atmospheric engines is unlimited.
	x	The total cylinder capacity of atmospheric engines is limited to 3700 cc.
x	x	The intake is regarded as the whole between the throttle valve box (included) and the intake port on the cylinder head.
x	x	Intake is free. For homologated cars, the intake needs to be in conformity with their homologation file. For monobrand cup cars, the intake needs to be in conformity with the homologation file or Technical File, and the Cup regulation.

5.4 Air intake system

T	GT	Restrictors
x	x	It must be possible to install a restrictor on any normally aspirated engine if deemed necessary by the stewards.
x	x	For monobrand cup cars, the restrictor needs to be in conformity with the homologation file or Technical File, and the Cup regulation.
x	x	When using one or more restrictors, all the air towards the engine needs to be led through these restrictors. No canal that can contain air, can come in or out the air box. Closing restrictors needs to immediately result in the stopping of the engine (3 sec.). This check needs to be made during an engine speed of 2500 tr/min. For this check, the

		pressure receptors and safety valves can be dismantled and the assembly interfaces of these sensors or valves will be covered.
x	x	RACB Sport reserves the right to, in agreement with the promoter, change the diameter of the restrictor, including for monobrand cup cars.

5.5 Engines with supercharger

T	GT	Engines with supercharger
x	x	The supercharging system is considered to be a tool that allows the raise in pressure of the mixture air-fuel in the internal combustion engine (compared to the pressure of the normal atmospheric pressure, the effect of inertia and the dynamic effects in the intake and/or exhaust system), in any given way. The injection of fuel under pressure is not regarded as supercharging. It can consist of a turbo, compressor, heat exchanger, element and piping of the supercharging, system regulator...
x	x	If the supercharging system is not original nor homologated on the original vehicle, the system must be approved by the RACB Sport prior to use.
x	x	The brand as well as the type of the supercharging system need to be specified on the passport of the car.

5.6 Control system

T	GT	Control system
x	x	Cars with supercharged engines cannot be equipped with a system that allows the pilot to adapt or change the supercharger or the electronic system that controls the supercharger while driving.

5.7 Water vaporiser or injection

T	GT	Water vaporising
x	x	The internal and/or external water vaporising, spraying or the injection of water or of another substance is prohibited (with the exception of the fuel necessary for the normal engine combustion).

5.8 Cooling

T	GT	Cooling
x	x	The cooling system is free, but the radiator needs to remain in its original position.

5.9 Exhaust

T	GT	Exhaust
x	x	The exhaust system is free, on the condition that it is made of mild or stainless steel with a minimum thickness of 1 mm. It needs to have at least one silencer through which all exhaust gasses must flow. Variable exhaust systems are not allowed, with the exception of a waste gate for supercharged engines.

		<p>The orifices of the exhaust pipes must be placed at a maximum of 45 cm and a minimum of 10 cm from the ground.</p> <p>The exit of the exhaust pipe must be situated within the perimeter of the car and less than 10 cm from this perimeter, at the back of the car (after the rear wheels).</p> <p>Moreover, adequate protection must be provided in order to prevent heated pipes from causing burns.</p> <p>The exhaust system must not be provisional.</p> <p>Exhaust gas may only exit at the end of the system.</p> <p>All cars must be fitted with an original or homologated catalytic exhaust that work at all times and through which all exhaust gasses must flow. A possibility of control needs to be provided in the proximity of the catalytic converter.</p>
x	x	<p>The noise produced by a car will be determined based on the regulation and the imposed limits, written in the special race regulation, or the limits imposed by the visited circuit, during the meeting.</p>

Art 6. FUEL LINES, FUEL PUMPS AND FUEL TANKS

T	GT	Fuel lines, pumps and fuel tanks
	x	The fuel system is free, on the condition that it meets the prescriptions in art. 6.1 to 6.7.
x		<p>For homologated cars, the fuel system needs to be in conformity with their homologation file.</p> <p>For monobrand cup cars, the fuel system needs to be in conformity with the homologation file or Technical File, and the Cup regulation.</p>

6.1 Fuel tanks and pumps

T	GT	Fuel tanks and pumps
x	x	<p>The fuel tank needs to be placed in its original place or in the trunk/luggage compartment. It needs to be separated from the pilot and the engine compartment by a water- and fireproof bulkhead and it needs to be surrounded by a compressible structure.</p>
x	x	<p>The original fuel tank can only be replaced by a FIA FT3-1999, FT3.5- or FT5-1999 fuel tank.</p> <p>Each FIA tank must have a marking with the following information :</p> <ul style="list-style-type: none"> • Name of the FIA standard • FIA homologation number • Name of the manufacturer • Serial number • Date of end of validity <p>No bladder may be used more than 5 years after the date of manufacture, unless inspected and recertified by the manufacturer for a period of up to another two years.</p> <p>A leak-proof cover, made from non-flammable material, easily accessible and removable only with the use of tools, must be installed in the protection for tanks, in order to allow the checking of the validity expiry date.</p> <p>The use of safety foam in FT3-1999, FT3.5-1999 or FT5-1999 tanks is recommended.</p>

6.2 Assembly of the fuel tank

T	GT	Assembly of the fuel tank
x	x	<p>The substitute tank needs to be fixed in a permanent way with a metal clamping system. If the fuel tank is installed under the car, it needs to be placed in a fireproof, close fitting case that does not offer any aerodynamic advantages and does not have any other mechanical function.</p> <p>This case needs to be equipped with a compressible structure at every external surface and needs to be fixed to the floor plane through minimum 2 metal clamps (30 mm x 3 mm) by means of bolts and nuts.</p> <p>For the installation of these clamps, the bolts need to have a minimum quality of 10.9 and a minimum diameter of 10 mm. A reinforcement plate of minimum 3 mm thick and with a surface of minimum 20 cm² above the floor plate needs to be installed under each bolt.</p> <p>The compressible structure needs to be of the type 'honeycomb sandwich panel', equipped with a fireproof core with a minimum compressibility of 18N/cm².</p> <p>The use of aramid fibres is allowed.</p> <p>The sandwich panel needs to have two sheets of 1,5 mm with a tensile strength of minimum 225 N/mm² and of which the minimum thickness is 1 cm.</p> <p>The other openings – after removing the original tank – can be closed using a panel of the same dimensions.</p> <p>Any change of the tanks or change of the position of the tanks must not give rise to any lightening or reinforcements other than those provided for under Article 255-5.7.1 of FIA Appendix J but the opening remaining after the removal of the original tank may be closed by the installation of a panel.</p>

6.3 Accessories and pipes

T	GT	Accessories and pipes
x	x	<p>Lines containing fuel or hydraulic fluid may pass through the cockpit, but without any connectors inside except on the front and rear bulkheads according to Drawings 253-59 and 253-60.</p> <p>Fuel lines must be changed for aviation type lines, the route of these lines being free.</p> <p>The installation of fuel lines is free, as long as they respect the FIA regulations of Annex J Art. 253-3.</p> <p>Fuel lines must be protected externally against any risk of deterioration (stones, corrosion, mechanical breakage, etc.) and internally against all risks of fire and deterioration.</p>

6.3.1 Automatic fuel cut-off

T	GT	Automatic fuel shutdown
x	x	<p>Recommended for all : All fuel feed pipes going to the engine must be provided with automatic cut-off valves located directly on the fuel tank which automatically close all the fuel lines under pressure if one of these lines in the fuel system is fractured or leaks.</p> <p>Compulsory : All the fuel pumps must only operate when the engine is running, except during the starting process.</p>

6.3.2 Fuel cell ventilation

T	GT	Vent of the fuel tank
x	x	<p>The ventilation line of the fuel cell as far as the valves described below must have the same specifications as those of the fuel lines and must be fitted with a system complying with the following conditions :</p> <ul style="list-style-type: none"> • Gravity activated roll-over valve • Float chamber ventilation valve • Blow-off valve with a maximum over pressure of 200 mbar, working when the float chamber ventilation valve is closed. <p>If the internal diameter of the fuel tank breather venting tube is greater than 20 mm, a non-return valve homologated by the FIA and as defined in Article 253-14.2 must be fitted.</p>

6.4 Fuel filling system

T	GT	Fuel filling system (car)
x	x	<p>The position and the dimension of the filler hole as well as that of the cap may be changed as long as the new installation does not protrude beyond the bodywork and guarantees that no fuel leaks into one of the interior compartments of the car.</p> <p>If the filler hole is situated inside the car, it must be separated from the cockpit by a liquid-tight protection.</p> <p>There must be an orifice to evacuate any fuel which may have spread into the tank compartment.</p>
x	x	<p>All cars fitted with a fuel tank with filler neck passing through the cockpit must be equipped with a non-return valve homologated by the FIA (Technical List n°18). This valve, of the type "with one or two flaps", must be installed in the filler neck on the tank side. The filler neck is defined as being the means used to connect the fuel filler hole of the vehicle to the fuel tank itself.</p>

6.5 Refuelling

T	GT	Refuelling
x	x	Refuelling during races is not allowed.

6.6 Fuel on board

6.6.1 Temperature

T	GT	Temperature
x	x	Storing fuel on board of the car at a temperature lower than 10°C under the prevailing outside temperature, is not allowed. The use, whether or not on board, of any equipment meant to turn the temperature of the fuel lower than the prevailing outside temperature, is not allowed.

6.6.2 Fuel tank capacity

T	GT	Fuel tank capacity
x	x	The maximum fuel capacity, including fuel tank and feed tank (with a maximum capacity of 1 litre) is maximum 120 litres,. Other fuel volumes can be limited by specific regulations, e.g., the monobrand cup regulations or the BOP decided by the promoter. Every system, procedure, construction, or design that has been designed to (temporarily) raise the volume in any given way to more than the allowed maximum litres, is prohibited. Other fuel types than gasoline and diesel are not allowed. Checks can be held by weighing the difference between the weight of the car with an empty fuel tank and the weight of the car with a full fuel tank. For all technical checks, the 120 litres fuel will be considered as weighing 91 kg; 102 kg in case of diesel, and 61 kg for 80L gasoline; and this at any given moment and in all circumstances.

Art 7. LUBRICATION SYSTEM

T	GT	Lubrication system
x	x	The lubrication system is free, on the condition that it meets the regulations in art. 7.1 to 7.2.
x	x	For homologated cars, the lubrication system needs to be in conformity with their homologation file. For monobrand cup cars, the lubrication system needs to be in conformity with the homologation file or Technical File, and the Cup regulation.

7.1 Oil tanks

T	GT	Oil tanks
x	x	No part of the car containing oil may be situated behind the complete rear wheels. All oil tanks must be properly protected. All oil tanks situated outside the main structure of the car must be surrounded by a 10 mm thick crushable structure. The oil tanks cannot be placed in the cockpit.

7.2 Oil catch tank

T	GT	Oil catch tank
x	x	<p>If the lubrication system includes an open type sump breather, it must be equipped in such a way that the oil flows into a catch tank. This must have a capacity of 2 litres for cars with a cubic capacity equal to or below 2000 cm³, and 3 litres for cars with a cubic capacity of over 2000 cm³.</p> <p>This container must be made either out of plastic or must include a transparent window. The dump tank needs to be assembled using solid, fireproof materials and needs to be equipped with a ventilation.</p> <p>Placing the oil dump tank in the cockpit is not allowed. The collection and ventilation points of the dump tank need to form the highest points of the tank. The sump breather cannot be freely pointed to the ground.</p>

Art 8. ELECTRICAL EQUIPMENT

T	GT	Electrical equipment
x	x	The electrical system is free, on the condition that it meets the regulations in art. 8.1 to 8.4.
x	x	<p>For homologated cars, all electrical systems need to be in conformity with their homologation file.</p> <p>For monobrand cup cars, all electrical systems need to be in conformity with the homologation file or Technical File, and the Cup regulation.</p>

8.1 Battery

T	GT	Battery
x	x	<p>The make, capacity, and battery cables are free.</p> <p>Its location is free.</p> <p>A wet battery must be covered by a leak proof plastic box, attached independently of the battery.</p> <p>The battery must be of the dry type if it is not in the engine compartment.</p> <p>If installed in the cockpit, the battery must be situated behind the base of the driver's or codriver's seat, or in a place that will not hinder the exit of the driver.</p>
x	x	<p>Each battery must be securely fixed and the positive terminal must be protected.</p> <p>Should the battery be moved from its original position, it must be attached to the body using a metal seat and two metal clamps with an insulating covering, fixed to the floor by bolts and nuts.</p> <p>For attaching these clamps, metallic bolts with a diameter of at least 10 mm must be used, and under each bolt, a counterplate at least 3 mm thick and with a surface of at least 20 cm² beneath the metal of the bodywork.</p>

8.2 Windshield wiper

T	GT	Windshield wiper
x	x	Motor, position, blades and mechanism are free but there must be at least one windscreen wiper provided for the windscreen in front of the driver and operational for the whole duration of the meeting. The headlamp washer device may be dismantled.

8.3 Starter motor

T	GT	Starter motor
x	x	A starter that functions during the whole duration of the race needs to be installed. The driver needs to be able to operate the starter from a normal driving position. For the settling or tuning of the engine, starting can also be done by means of an external battery. The connection to the external battery needs to be located within the safety cage and must use a special plug. Under no circumstances, can this connection be placed under the hood or in the direct proximity of the fuel tank or fuel lines. When the car wants to continue the race after a pit stop, all the wheels need to touch the ground before starting the engine and this from a seated position behind the steering wheel and without external equipment.

8.4 Lighting

8.4.1 Procedure

T	GT	Procedure
x	x	During trainings and races, every car must be equipped with efficient lighting. The original lights or lights included in the manufacturer's catalogue need to be used. The lights need to remain in their original location. Lightening these lights is allowed. Every car must be equipped with at least (functioning): <ul style="list-style-type: none"> ▪ At the rear of the car: two red stop lights, two normal red lights and two orange direction indicators; these need to be installed at each side of the car, symmetrically towards the longitudinal axis, so they are visible. A red rain light is also mandatory. ▪ Front: at least two white lights and two orange direction indicators. ▪ The light bulbs of the reverse gear lights must be removed. ▪ As soon as the session is declared WET by the race director, or as soon as rain tyres or tyres that cause splashing water are used, the driver needs to turn on the lights and the rain light of the car. ▪ Headlight covers can be installed. When the panel 'LIGHT' is shown on track, the car must immediately go into its box in order to have the covers removed. <p>If, following an incident during the race, a car has problems with the lights, it can remain on the racetrack if at least one front and one rear light functions. Identical, also one stop light needs to function. If the circumstances of the race require it, the rain light must be operational.</p>

8.4.2 Rain light

T	GT	Rain light
x	x	<p>All cars must have at least one rain light approved by the FIA (Technical list n°19) which must be in working order throughout the competition, and which :</p> <ul style="list-style-type: none"> - Faces rearward and is clearly visible from the rear; - Is mounted no less than 400 mm from the ground; - Is mounted no more than 100 mm from the car centreline or, in the case of two lights, are mounted symmetrically on either side of the longitudinal axis of the car on the bodywork behind the rear wheels in frontal projection; - Can be switched on by the driver when he is seated normally in the car.

8.4.3 Illumination of the race numbers during night sessions

T	GT	Illumination of the race numbers during night races
x	x	<p>If a race is held in the dark, the lateral race numbers need to be illuminated. These lights need to be lit together with the headlights. Using illuminated backgrounds is recommended, but not mandatory.</p> <p>At no point in the race can a white light be pointed rearwards, not even in order to illuminate the race numbers, nor the numbers meant for the identification of the car.</p> <p>At no point in the race can a red light be pointed forwards, not even the lights meant to illuminate the race numbers, nor the lights for the identification of the car.</p> <p>It is prohibited to use flashing lights or rotating lights.</p>

Art 9. TRANSMISSION

T	GT	TRANSMISSION
x	x	The transmission is free on the condition that it meets the regulations in art. 9.1 to 9.4 and that it respects the original position.
x	x	For homologated cars, transmission must be in conformity with their homologation file. For monobrand cup cars, transmission must be in conformity with the homologation file or Technical File, and the Cup regulation.
x	x	A four-wheel drive car can be changed into a two-wheel drive car.
x	x	For safety reasons, the transmission must be designed so that if the car stops and the engine shuts off, it becomes possible to push or pull it.

9.1 Changing gear

T	GT	Changing gear
x	x	<p>The gear shifting mechanism (connection between the gearbox and the gear lever, handled by the pilot) is free.</p> <p>The system known as 'Gear Shifter', which facilitates gearing through an action on the operation of the engine (ignition or injection), by means of an interruption activated while moving the gear lever, is allowed.</p> <p>If the original car or a Cup version is equipped with a semi-automated or automated gearbox, it can be maintained. In that case, the gearbox and its synchronisation, as well as the complete control system need to remain original or meet the regulations of the Cup, or the homologation file.</p>

9.2 Differential

T	GT	Differential
x	x	Differentials with electronic, pneumatic or hydraulic management are forbidden. The use of a mechanical type limited slip differential is authorised. "Mechanical limited slip differential" means any system which works purely mechanically, i.e. without the help of a hydraulic or electric system. A viscous clutch is not considered to be a mechanical system.

9.3 Gearbox

T	GT	Gear box
x	x	The interior of the gear box is free. The gear ratios are free, but they need to be included in the passport of the car at the start of the season. In case of modification to these ratios, the participant needs to communicate it and have it included in the technical passport before the meeting. The gear box must have a maximum of 6 forward gears and 1 reverse gear. All cars must have a reverse gear which must be in working order throughout the competition. It must be possible for the driver to select reverse gear while seated normally at the wheel and with the engine running.

9.4 Clutch

T	GT	Clutch
x	x	Only a conventional mechanical design is allowed. The material is free. The clutch can only be activated by the pilot's foot, except in case of a semi-automated or automated gear box. An exception is possible for disabled pilots.

Art 10. SUSPENSION AND STEERING MECHANISM BGDC

T	GT	Suspension and steering mechanism
x	x	The suspension and the steering mechanism are free, on the condition that they meet the regulations in art. 10.1 to 10.8.
X	X	For homologated cars, suspension and steering mechanism must be in conformity with their homologation file. For monobrand cup cars, suspension and steering mechanism must be in conformity with the homologation file or Technical File, and the Cup regulation.

10.1 Type of suspension and assembly

T	GT	Type of suspension and assembly
x	x	Every form of active suspension is prohibited. Every automated or electronic steering system or chassis and suspension control system is prohibited, even if it is homologated for road use. This includes, among others, dampers, suspension and ride height control systems.

		<p>The suspension cannot solely consist of bolts that pass in flexible tubes and/or installations. The wheels need to be able to move with a suspension travel bigger than the one caused by flexible connections.</p> <p>Flexible joints can be replaced by metal joints (e.g. uniball joints). The fixation points to the frame or chassis need to be respected, with the exception of cases approved by the FIA.</p>
--	--	---

10.2 Springs

T	GT	Springs
x	x	The material, dimensions and the number of springs are free.

10.3 Shock absorbers 255 page 12,

T	GT	Shock absorbers
x	x	<p>Shock absorbers are free as long as the number of shock absorbers per wheel does not exceed the number of the original car.</p> <p>All shock absorbers must be independent of each other. Inertia shock absorber systems are prohibited.</p> <p>If the shock absorbers have separate fluid reserves located in the cockpit, or in the boot if this is not separated from the cockpit, these must be strongly fixed and must have a protection.</p>

10.4 Adjustments

T	GT	Adjustments
x	x	<p>The modification of spring and shock absorber adjustments from the cockpit is prohibited.</p> <p>Antiroll bars that are adjustable from the cockpit are prohibited.</p>

10.5 Material

T	GT	Material
x	x	All suspension arms need to be made of homogeneous metallic materials. Chroming of steel suspension arms is prohibited.

10.6 Steering mechanism

T	GT	Steering mechanism
x	x	<p>The steering system and its position are free, but it must be commercially available. Only a direct mechanical linkage between the steering wheel and the steered wheels is permitted.</p> <p>The steering column must be fitted with a retractable device in case of impact, coming from a series vehicle.</p> <p>The locking system of the anti-theft steering lock may be rendered inoperative.</p>

		<p>The column adjusting system must be locked and must be operated only with tools.</p> <p>The steering wheel can be replaced or can be fitted with a quick release mechanism in compliance with Article 255-5.7.3.9 of FIA Appendix J.</p> <p>The quick release mechanism must consist of a flange concentric to the steering wheel axis, coloured yellow through anodisation or any other durable yellow coating and installed on the steering column behind the steering wheel.</p> <p>The release must be operated by pulling the flange along the steering wheel axis.</p>
--	--	---

10.7 Power steering

T	GT	Power steering
x	x	<p>Hydraulic, electro-hydraulic or electric power assisted steering systems are allowed on the condition that it consists of a simple system without programmable steering.</p> <p>Power steering may be disconnected but not removed.</p> <p>Any steering system which permits the re-alignment of more than two wheels is forbidden.</p> <p>No such system may have any function other than that of reducing the physical effort required to steer the car.</p>

10.8 All-wheel steering

T	GT	All-wheel steering
x	x	Four-wheel steering is forbidden.

Art 11. BRAKES

T	GT	Brakes
x	x	The brake system is free, on the condition that it meets the regulations in art. 11.1 to 11.6.
x	x	<p>For homologated cars, braking system must be in conformity with their homologation file.</p> <p>For monobrand cup cars, braking must be in conformity with the homologation file or Technical File, and the Cup regulation.</p>

11.1 Dual-circuit brake

T	GT	Dual-circuit brake
x	x	<p><u>Double circuit operated by the same pedal :</u></p> <p>The pedal must normally control all the wheels; in case of a leakage at any point of the brake system pipes or of any kind of failure in the brake transmission system, the pedal must still control at least two wheels.</p> <p>The brake fluid tanks may be fixed inside the cockpit. In that case, they must be securely fastened and be protected by a liquid and flame proof covering.</p>

11.2 Brake discs

T	GT	Brake discs
x	x	The brake discs are free but need to be made from ferrous material. If the production vehicle has brake discs made of non-ferrous material, they can be maintained. The material for the brake pads is free.

11.3 Pedalbox and anti-blocking system

T	GT	Pedal and anti-blocking system
x	x	The mounting of a pedalbox is allowed. Servo-brakes, anti-blocking systems, ... and other original accessories can be removed. A manually operated hydraulic brake pressure regulator that affects the rear brakes, is allowed and can be placed in the cockpit, within reach of the pilot, while sitting in a normal driving position, with safety belts on. A mechanical brake balance system front/rear is allowed provided it is manually operated.

11.4 Brake callipers

T	GT	Brake callipers
x	x	The internal parts of the brake callipers can be made of titanium. One single calliper per wheel with a maximum of 6 pistons per calliper is allowed. The contact area of each piston of the brake calliper must be circular.

11.5 Brake lines

T	GT	Brake lines
x	x	Brake lines may be changed for aviation type lines. Brake lines must be protected externally against any risk of deterioration (stones, corrosion, mechanical breakage, etc.) and internally against all risks of fire and deterioration. Lines containing fuel or hydraulic fluid may pass through the cockpit, but without any connectors inside except on the front and rear bulkheads according to Drawings 253-59 and 253-60, and on the braking circuit and the clutch fluid circuit.

11.6 Cooling of brakes

T	GT	Cooling of the brakes
x	x	Protection shields may be modified or removed, but material may not be added. Only one flexible pipe to bring the air to the brakes of each wheel is allowed, but its inside section must be able to fit into a circle with a 10 cm diameter. This pipe may be doubled, but in that case the inside section of each pipe must be able to fit into a circle with a 7 cm diameter. The air pipes must not go beyond the perimeter of the car, seen from above. The air canals cannot exceed the perimeter of the vehicle, when viewed from above. External cooling of the brakes by means of fluid is forbidden. Cooling systems connected to the wheels are forbidden.

Art 12. WHEELS AND TIRES

T	GT	Wheels and tires
x	x	For homologated cars, wheels diameter, width and offset must be in conformity with their homologation file. For monobrand cup cars, wheels diameter, width and offset must be in conformity with the homologation file or Technical File, and the Cup regulation.
x	x	It is forbidden to remove or modify the marking of the tires.

12.1 Definitions

T	GT	Definitions
x	x	Wheel = Hub + rim Complete wheel = Hub + rim + tire mounted on the wheel

12.2 Dimensions BGDC

T	GT	Dimensions
x		Maximum diameter of the wheel: 18"
x		Maximum diameter of the complete wheel : 650 mm

12.3 Visibility of the wheels

T	GT	Visibility
x	x	When viewed from above and with the wheels placed straight ahead, the upper part of the complete wheel, located vertically over the wheel hub centre cannot be visible and must be covered by the bodywork. The wheels need to be placed in such a way that the vehicle moves straight ahead.

12.4 Material of the wheels

T	GT	Material of the wheels
x	x	The material used for the wheels is free, on the condition that it is a homogeneous metallic material. Wheels made from forged magnesium are forbidden (including standard wheels). Wheel covers need to be removed. Wheels cannot show signs of cracks and they need to be clean when being introduced during the technical check.

12.5 Number of wheels

T	GT	Number of wheels
x	x	The maximum number of wheels on a car is four. Per axis, the wheels need to be of the same type, material and dimensions. A spare wheel cannot be present in the car.

12.6 Wheel fixing

T	GT	Wheel fixing
x	x	<p>Fixing the wheel to the frame is free. If only one central hub fixation is used, it must be secured with a red or orange safety spring release or split pin while the car is moving. After every tyre change, these need to be installed again. Other methods to retain the wheels can be used, on the condition that they are allowed by the FIA.</p> <p>Wheels fixations by bolts may be changed to fixations by pins and nuts provided that the number of attachment points and the diameter of the threaded parts as indicated on Drawing 254-1 are respected.</p> <p>The wheel nuts may be changed, provided that their material remains iron-based alloy.</p> <p>If wedges or track extensions are mounted, they need to be fixed to the wheel hub or to the brake disc bell in a mechanical way.</p> <p>Air extractors added on the wheels are forbidden.</p>

12.7 Pneumatic jacks

T	GT	Pneumatic jacks
x	x	The use of pneumatic jacks is allowed, but bottles with compressed air cannot be placed in the car.

12.8 Check of the tyre pressure

T	GT	Check of the tyre pressure
x	x	<p>The use of any device for maintaining the performance of the tyre with an internal pressure equal to or less than the atmospheric pressure is forbidden.</p> <p>The interior of the tyre (space between the rim and internal part of the tyre) must be filled only with air. No additive whatsoever (gas, fluid ...) is allowed.</p> <p>All regulation systems for tyre pressure, e.g. pressure relief valves, are forbidden.</p> <p>The use of valve caps is necessary.</p>

Art 13. COCKPIT

T	GT	Cockpit
x	x	<p>For homologated cars, cockpit must be in conformity with their homologation file.</p> <p>For monobrand cup cars, cockpit must be in conformity with the homologation file or Technical File, and the Cup regulation.</p>

13.1 Cockpit equipment

13.1.1 Dashboard

T	GT	Dashboard
x	x	The dashboard needs to be maintained. Lightening or modifying the dashboard is allowed.
x	x	The instruments are free.
x	x	The original switches can be replaced by other switches of a different design. They can be placed in another location on the dashboard or console.

13.1.2 Components that must be removed from the cockpit:

T	GT	Components that must be removed from the cockpit:
x	x	Sound insulating material and coating against the roof (inside the cockpit). car and floor mats, and insulating materials. Steering lock (see Article 10.6) Airbags Passenger seat and rear seats

13.1.3 Components that can be removed from the cockpit:

T	GT	Components that can be removed from the cockpit:
x	x	All coatings and sound insulating materials. After removal, all sharp edges need to be protected efficiently. Air-conditioning, original safety belts and their roll-up mechanism, electrical window mechanisms, central door locks, radio, horn, glove box, central console, rear shelf, instruments, door pockets and other parts that, in the original car, only offer comfort to the passengers. The original system for ventilation, demisting and heating can be removed, but an adequate ventilation and demisting of the cockpit is mandatory.
x	x	No moving/flying part can be found in the cockpit when the car is running.

13.2 Equipment that can be installed the cockpit:

T	GT	Equipment allowed in the cockpit:
x	x	<ul style="list-style-type: none"> ▪ Safety structure and equipment ▪ Toolkit, only if firmly fixed ▪ Driver seat, instruments and other parts necessary for driving, including brake pressure regulator ▪ Electronic and electrical equipment ▪ Cooling system for the pilot ▪ Ballast ▪ Pneumatic jacks and their pipes ▪ Battery ▪ Ventilation equipment for the pilot ▪ Door covering <p>None of the items above can hinder the cockpit exit or the visibility of the driver.</p>

Art 14. SAFETY EQUIPMENT

14.1 Safety equipment « Car »

14.1.1 Fire extinguishers

T	GT	Fire extinguisher
x	x	<p>All cars must be equipped with an extinguishing system in compliance with FIA Standard for plumbed-in Fire Extinguisher Systems in Competition Cars (1999) or with FIA Standard 8865-2015 as detailed in FIA Appendix J Art. 253-7.1.</p> <p>The system must be used in accordance with the manufacturer's instructions and with Technical Lists n°16 or n°52.</p> <p>All extinguisher containers must be adequately protected and must be situated within the cockpit.</p> <p>The container may also be situated in the luggage compartment on condition that it is at least 300 mm from the outer edges of the bodywork in all horizontal directions.</p> <p>It must be secured by a minimum of 2 screw-locked metallic straps and the securing system must be able to withstand a deceleration of 25 g.</p> <p>Anti-torpedo tabs are required.</p> <p>The material of the securing system must operate within the -15°C to +80°C temperature range.</p> <p>All extinguishing equipment must withstand fire.</p> <p>Plastic pipes are prohibited and metal pipes are obligatory (unless specified otherwise).</p> <p>The driver (and co-driver where applicable) must be able to trigger the extinguishing system manually when seated normally with his safety harnesses fastened and the steering wheel in place. Furthermore, a means of triggering from the outside must be combined with the circuit-breaker switch. It must be marked with a letter "E" in red inside a white circle of at least 10 cm diameter with a red edge.</p> <p>The system must work in all positions.</p> <p>Extinguisher nozzles must be suitable for the extinguishant and be installed in such a way that they are not directly pointed at the occupants' heads.</p>

14.1.2 Safety harness

T	GT	Safety harness
x	x	<p>The use of a safety harness in compliance FIA Appendix J Article 253-6 is mandatory.</p> <p>Only harnesses compliant with FIA 8853/98 or FIA 8853-2016 Standard are allowed.</p> <p>The harnesses used in circuit races must be equipped with turnbuckle release systems.</p> <p>Installation and use must comply with FIA Appendix J Article 253-6.</p>

14.1.3 Rear-view mirror

T	GT	Rear-view mirrors
x	x	Rearward visibility must be ensured by two external rear-view mirrors (one on the right and one on the left). These rear-view mirrors may be as standard. Each rear-view mirror must have a reflecting surface of at least 90 cm ² . An inside rear-view mirror is optional.

14.1.4 Seat

T	GT	Seat
x	x	All the occupants' seats must be homologated by the FIA (8855-1999, 8855-2021 or 8862-2009 standards), and not modified. They must be situated ahead of the main rollbar (or the rear pillar of the lateral rollbar) of the safety cage (Cf. Art. 253-8). Installation and use must comply with FIA Appendix J Article 253-16.

14.1.5 Circuit and voltage breaker

T	GT	Circuit / voltage breaker
x	x	A general circuit breaker is mandatory and must comply with FIA Appendix J Article 253-13. It must cut all electrical circuits, battery, alternator or dynamo, lights, hooters, ignition, electrical controls, etc.) and must also stop the engine. For Diesel engines having no electronically controlled injectors, the circuit breaker must be coupled with a device cutting off the intake into the engine. It must be a spark-proof model and must be accessible from inside and outside the car. The must be able to reach the general circuit breaker inside the cockpit while sitting in a normal driving position with tight seatbelts and with the steering wheel in place. As for the outside, the triggering system of the circuit breaker must compulsorily be situated at the lower part of the windscreen mountings for closed cars. It must be marked by a red spark in a white-edged blue triangle with a base of at least 12 cm.

14.1.6 Towing eyes

T	GT	Towing eyes
x	x	All cars must be equipped with a rear and front towing-eye for all competitions. This towing-eye will only be used if the car can move freely. These towing eyes must be : <ul style="list-style-type: none"> - clearly visible and painted in yellow, red or orange. - Solid, made of steel, unbreakable, with an inner diameter between 60 and 100 mm and a thickness of 5 mm, or be homologated if it is a belt type made from soft material. - Rounded off, so they don't damage or cut the straps of the marshals. - Firmly fixed to the chassis by means of a solid part made of steel (steel cables that form a loop are forbidden). - Located within the perimeter of the bodywork, when viewed from above.

		<ul style="list-style-type: none"> - placed in such a way that it can be used should the car be stopped in a gravel bed. <p>Moreover, the precise place of the towing eyes needs to be marked with an arrow in a contrasting colour on the bodywork.</p>
--	--	---

14.2 Safety equipment “driver”

The complete personal equipment needs to be in conformity with FIA Appendix L – Chapter III of the current FIA International Sporting Code.

The complete personal equipment must be shown during the technical scrutineering.

14.2.1 Helmet

Wearing a homologated helmet, for usage with a head and neck protection system (FHR system), is mandatory when the car is in motion. The helmet needs to meet at least one of the valid standards found in FIA Technical List n° 25.

The helmet needs to be equipped with tether anchors with the FIA code 8858-2002 or 8858-2010 and the accompanying FIA hologram sticker.

14.2.1.1 Modifications (Annex. L chapter. III 1.2)

No helmet can be modified compared to its manufacturing data.

14.2.1.2 Communication system (Annex. L chapter. III 1.3)

A radio communication system or headphone mounted in the helmet is forbidden. A hearing device, directly into the ear (type ear plug) is allowed.

Deviations solely for medical reasons can be approved by the medical commission of RACB Sport. A microphone can only be installed if it meets the prescriptions of the FIA (Annex L, chap. III, art. 1.2).

14.2.1.3 Decoration

Needs to meet the standards according to Annex L Chapter III 1.4 of the current FIA yearbook.

14.2.2 Head and neck protection system (FHR system) (Annex. L Chapter III 3)

The use of a head and neck restraint system (FHR) is mandatory.

The list of systems (8858-2002 and 8858-2010) and helmets approved by the FIA can be found on the technical list n° 29 and n°41. The tethers need to be equipped with the FIA homologation label 8858-2002 or 8858-2010 (see table in Annex L chapter III-3.3 for intercompatibilities).

14.2.3 Fireproof clothes (Annex L Chapter III 2)

The driver must wear a fireproof overall. The overall must meet the FIA standard 8856-2000 or FIA 8856-2018.

Furthermore, the pilot must wear long underwear, a balaclava, socks, shoes and gloves that meet the design and the parameters for the manufacturing, imposed by the FIA standard 8856-2000 or FIA 8856-2018.

The FIA homologated fireproof clothing can be found in the technical list n° 27 (FIA 8856-2000) and n° 74 (FIA 8856-2018).

Art 15. SAFETY STRUCTURE

15.1 Structure of the safety cage

T	GT	Structure of the safety cage
x	x	<ul style="list-style-type: none"> The car needs to be equipped with a safety cage that complies with Art. 253-8 of Annex J of the current FIA regulation. Every modification to a homologated safety cage is strictly forbidden and would lead to the safety cage being no longer conform. Intermediate door supports in longitudinal direction, approved by the FIA, that ensure a lateral protection, need to be present, in agreement with drawings 253-8, 253-9, 253-10 and 253-11 of Annex J of the current FIA regulation.
x	x	The safety structure needs to be approved by the FIA or an ASN.
x	x	<p>The tubes of the safety cage, that can come into contact with the body of the pilot, must be covered with fireproof material.</p> <p>Where the helmet can come into contact with the safety cage, the coating of the latter needs to at least comply with the FIA standard 8857-2001 type A.</p> <p>It is forbidden to assemble electrical, fuel or other lines between the safety cage and the bodywork.</p>

15.2 Fire-resistant bulkhead

T	GT	Fire-resistant bulkhead
x	x	<p>An efficient protective screen must be placed between the engine and the occupant's seat, in order to prevent the direct passage of flames in case of fire. Should this screen be formed by the rear seats, it is advisable to cover them with a flameproof coating.</p> <p>Any hole in a fire-resistant bulkhead must be so small, that they only allow the passage of lines and/or cables. These holes need to be completely closed and equipped with rubber grommets.</p>

15.3 Composite frame

T	GT	Composite frame
x	x	Any composite chassis must be homologated by the FIA or must be presented to RACB Sport for prior approval.

x	x	For every car equipped with a composite chassis, each reparation of the survival cell or the front protection needs to be made according to the specifications of the manufacturer, in one of the reparation centres, indicated by the manufacturer. For any repair work be undertaken on the chassis, a repair attest from the chassis manufacturer must be presented at the Technical Scrutineering. Every important damage needs to be included in the technical passport of the car.
----------	----------	--

Art 16. FUEL

16.1 Fuel specifications

T	GT	Fuel specifications
x	x	The fuel used must be a commercial fuel.

16.2 Air

T	GT	Air
x	x	For the preparation of the mixture, only air can be mixed with the fuel.

Art 17. CURRENT TEXT

The English text of the Technical Regulation will be the definitive text referred to in case of a dispute concerning the interpretation of this text. The titles of this document are only mentioned for the legibility and are not part of the current Technical Regulation.

Art 18. APPROVAL

Regulation approved by RACB Sport with Visa n° **T01-BSSC/B21**